

# Notes for a New Physics

## Second Edition with Changes and Additions

Giacinto Libertini

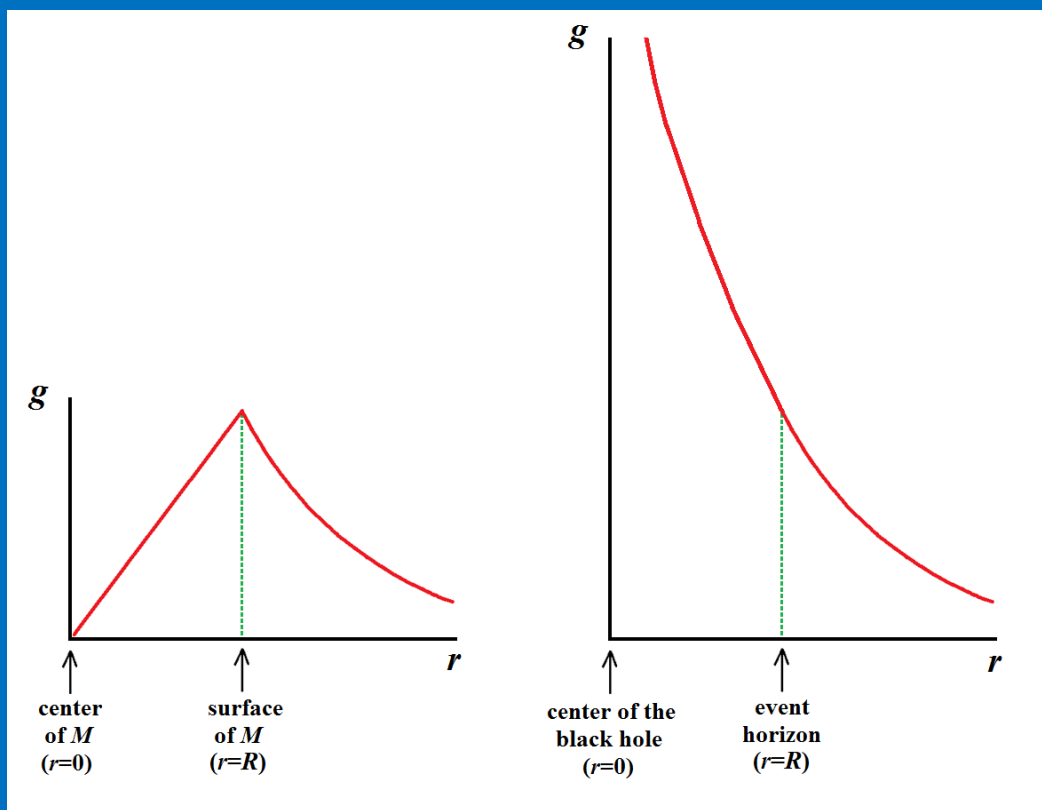

COPERNICAN EDITIONS

# **Notes for a New Physics**

**Second Edition with Changes and Additions**

**Giacinto Libertini**

**Copernican Editions**

Copyright © 2022  
Copernican Editions  
Naples, Italy

ISBN 978-88-906486-8-7

# Notes for a new physics

## Presentation of the Second Edition of Notes for a New Physics

A little over a year after the First Edition, even with the stimulus of the comments proposed in the public discussion concerning the First Edition, it seemed appropriate to me to propose a new edition that would correct and extend the previous one.

Some sections have been added that specifically address topics not covered in the First Edition:

- 22. The Time dimension
- 23. Subdivision of a dimension
- 24. The infinite

Other sections have been subject to substantial changes and additions. In particular:

- 2. A starting point
- 3. Possible spatial distortions that determine the “forces”
- 8. The mesons
- 9. Interpretation of some reactions with the vector bosons  $W^+$  and  $W^-$  and of some other reactions
- 13. Heisenberg’s uncertainty principle and its possible reformulation
- 15. Flattening and electromagnetic waves

Corrections, changes and improvements have been made in many places. Some figures have been added or modified.

I hope that my “heretical” proposal is now clearer and more worthy of evaluation.

Giacinto Libertini

## Summary

For the layman, modern physics is like an immense and magnificent cathedral that is impressive in its complex and sophisticated architecture, and amazing in size and richness of the workmanship. Yet, in this apparently almost complete building, there is no answer to a series of fundamental and crucial questions, while in any case these answers are indispensable and preliminary to any general theory.

It is essential to avoid confusion between appropriate and clarifying answers and false tautological answers or formulas that actually say nothing about the questions asked.

In this book, the starting point is the interpretation given by Einstein's general relativity to explain the gravitational force not as an action at a distance but as an intrinsic effect of the spatial distortions caused by the "masses". This interpretation is extended to the explanation of any attractive or repulsive "force" as an effect, for each "force", of the flattening of a specific dimension with positive or negative curvature.

The work offers, without any forcing, an explanation for most of the unsolved questions of physics: the nature of a mass, and of matter and antimatter, the structure of an atom, the origin of natural constants, the quantization of phenomena, etc. It also offers a different interpretation of the structure of electrons and black holes.

In addition, the existence of antimatter in protons is also predicted, but not in neutrons, a phenomenon that appears to be documented by recent works.

This book is not written by a physicist, but it also highlights why an academic physicist would have to overcome serious or insurmountable difficulties to give innovative answers to the fundamental unsolved problems of physics using concepts that are different from those currently accepted.

# Index

1. Introduction
2. A starting point
3. Possible spatial distortions that determine the “forces”
4. Effects of the General Law of Divergent/Convergent Deviations in the comparison among dimensions with different curvature
5. Quantization of our sub-universe
6. Model of the atom
7. About the quarks and their colors
8. The mesons
9. Interpretation of some reactions with the vector bosons  $W^+$  and  $W^-$  and of some other reactions
10. The Newtonian dimensions
11. Maximum speed and acceleration in a dimension
12. The black holes
13. Heisenberg’s uncertainty principle and its possible reformulation
14. Rotation of a segment of a dimension
15. Flattening and electromagnetic waves
16. Spatial and temporal changes caused by a greater velocity or acceleration
17. Description of a body rotating with uniform speed around another body
18. Description of a body that is attracted by another body
19. The entanglement
20. The anthropic principle
21. Origin of the bubbles or sub-universes
22. The Time dimension
23. Subdivision of a dimension
24. The infinite
25. Conclusion
26. Post scriptum
27. References

Appendix 1

Appendix 2

## 1. Introduction

For the layman, modern physics is like an immense and magnificent cathedral that is impressive in its complex and sophisticated architecture, and amazing in size and richness of the workmanship. It represents the fruit of the secular work by exceptional talents, among which there are many of the greatest scientific geniuses: Galilei, Newton, Einstein, Lemaître, Faraday, Maxwell, Planck, Curie, Thomson, Rutherford, Pauli, Fermi, Bohr, Heisenberg, Dirac, Schrödinger, Feynman, Gell-Mann, to name just a few.

For modern physics, large groups of powerful minds have been working and work using the most expensive, colossal and complex machines ever made for scientific research.

Modern physics could be considered as a formidable building in which only the definition of some important parts is missing: the insertion of the gravitational force into a single framework with the electromagnetic, strong and weak forces, a general theory that organizes everything in a coherent way, the answers to some particular questions, etc.

Yet, in this apparently almost complete building, there are no answers to a series of fundamental and crucial questions, while in any case these answers are indispensable and preliminary to any general theory.

For example:

- (1) What are the electromagnetic force, the strong force, the weak force and the red/green/blue forces acting within the nucleus?
- (2) Why do electric charges of the same sign repel each other while electric charges of opposite sign attract each other?
- (3) Which is the difference between positive and negative electric charges?
- (4) Why do not electrons with their negative charge fall on the surface of the nucleus that has a positive charge?
- (5) What are the colors of a quark?
- (6) Why are protons and neutrons composed of three quarks and not of a different number of quarks?
- (7) Why do quarks have electric charges that are a third or two thirds of that of electron or positron?
- (8) Why are all phenomena quantized?
- (9) Why do the values of light speed, Planck constant, universal gravitation constant, and electron charge have certain values?
- (10) How are the phenomena generally described as “entanglement” justified?
- (11) Which is the nature of an electromagnetic wave?
- (12) Why do electromagnetic waves, which run at the speed of light in a vacuum, do not shorten in the direction of their movement as occurs for any mass according to the theory of relativity?
- (13) Why are the weak force and the strong force extremely strong inside the nucleus and at the atomic level, respectively, but become irrelevant at slightly greater distances, while the gravitational force is extremely weak and negligible at the atomic level but does not lose its attractive capacity even at distances of billions of light years?
- (14) If it is true that in a Black Hole and in the singularity that is at its center all information is lost, how is this phenomenon justified?

The list of questions for which there are no answers is quite long. And it is essential to avoid the confusion between an appropriate and clarifying answer and false tautological answers of this type: the positive and negative charges are distinguished and defined for the different actions that an electromagnetic field has on them or for the actions that there are between them. Or answers consisting of formulas that actually say nothing about the questions posed. For many queries, there is the clear implicit admission of not having an answer when it is maintained that this is so because empirically confirmed.

How can we assume that physics is a building almost completed when answers are lacking for many fundamental and preliminary questions regarding the bases of most phenomena? In other words, for

modern physics there is not simply the lack of finishing touches or of some essential connections but of the very foundations of the whole structure.

Now, it is necessary to point out that I am not a physicist, I do not have the ability to understand or discuss the countless sophisticated formulas of modern physics or the formidable experiments that are carried out in the study of particles and in other branches of physics. Moreover, it is opportune to add that I have very limited and elementary mathematical skills. In short, my ignorance of modern physics and mathematics is such that it is not even worthy of evaluation. Yet, despite my enormous ignorance, I can understand the simplest concepts of physics and the existence of huge and critical gaps underlying the whole edifice of this central discipline.

Consequently, like the ancient Greek philosophers for whom ἡ φύσις (the physics) was a fundamental and essential part of philosophy, I can try to discuss certain basic questions. Yet, in a better position than the great philosophical minds of the past, I can take advantage of the results of centuries of experimental observations and the subsequent elaborations by giants of the science. This does not mean proposing elaborate constructions on theoretical and simplistic bases that neglect the experimental evidence: on the contrary, it is to be understood as seeking interpretations based on the results of modern physics but such as to give answers to the unresolved questions before highlighted. My profound ignorance is a big limitation but somehow an advantage. Due to my total inadequacy in this regard, I cannot try to deepen or improve the results of any branch of modern physics and I am forced to seek new ways for the interpretation of some basic phenomena of physics, giving an explanation for the aforementioned questions with simplicity accessible by my limited skills (s. Appendix 1).

## 2. A starting point

Perhaps a useful and essential starting point is the consideration of two huge and fundamental steps forward in the understanding of physical phenomena suggested in their time by Newton and Einstein. It is well known that Newton by his proposal of the law of universal gravitation provided an explanation, or rather a precise and general description, for a long series of both terrestrial and astronomical phenomena. Newton was well aware that the law of gravitation described the phenomenon of the attraction between masses, but that the law did not explain an apparent action at a distance. The great scientist declared that he did not know the nature of the gravitational force and how a body could exert a force of attraction on another body even at enormous distances.

Moreover, Newton did not want to hypothesize an explanation (“*hypotheses non fingo*” [Newton 1726], from the statement that in the English translation from Latin is: “I have not as yet been able to discover the reason for these properties of gravity from phenomena, and I do not feign hypotheses.” [Bernard Cohen and Whitman 1999, p. 943].

Einstein proposed a revolutionary interpretation of the law of gravitation. Any “mass” somehow modifies the space (or more precisely space-time) and also the geodesics (i.e., the shortest lines of connection between two points), which results in deviations of the movements of the other “masses” in the space-time. These deviations are interpreted as the effects of a “gravitational force”, but in fact such a force does not exist. (“The General Theory of Relativity tells us gravity is not a force, gravitational fields don’t exist. Objects tend to move on straight paths through curved space-time.” <https://www.youtube.com/watch?v=XRr1kaXKBsU>; accessed in September 2021) This answer provided an explanation of how an apparent action at a distance is consequence of space-time distortion.

Einstein’s explanation certainly requires clarifications (in particular, what a mass is and how it warps space-time), but opens the way to a possible generalization.

The weak force, the strong force, the electromagnetic force, the forces that repel “colors” of the same sign at the nuclear level, we could consider them all as causes of apparent “actions at a distance”. If Einstein’s explanation of gravitation is true (distortion of space-time -> deviations caused by the

modifications of space-time geodesics -> apparent existence of a force), is it possible to propose that all the other “forces” are expressions of analogous phenomena?

Now, a little digression is opportune. All natural phenomena in their roots can be described in physical-chemical terms, and considering that even chemistry is reducible to physical phenomena, all natural phenomena can be described in physical terms. At this point physics, the central discipline of science, could be the expression of a more or less long series of distinct kinds of phenomena or basic laws (hypothesis 1) or the expression of a single phenomenon that manifests itself in multiple ways that are only apparently distinct (hypothesis 2). The truth of one of these two hypotheses cannot be determined *a priori*, but must be sought on the basis of empirical evidence and subsequent rational arguments. The general orientation and aspiration are that hypothesis 2 is true (although it is not proven, like the other, and not necessarily true). However, if hypothesis 2 is true and if Einstein’s proposal is sound, all the “forces” should be explained in a similar way to that proposed for the gravitational force, that means: each of them is only apparently a force while in reality is the effect of convergent or divergent deviations resulting from changes in space-time geodesics (described as “attractive forces” and “repulsive forces”, respectively).

Following this thesis, we immediately encounter fundamental difficulties. A hypothetical valid solution should explain both the cases where there is “attraction” and the cases where there is “repulsion”.

In particular, any general solution should simultaneously explain:

- the attraction between two masses;
- if the suggestion of Villata [Villata 2011] is true, the attraction between two masses of antimatter and the repulsion between matter and antimatter;
- the repulsion between two electric charges of the same sign and the attraction between two electric charges of opposite sign;
- similarly, the attractions and repulsions related to weak and strong forces, and to the forces acting between the different “colors”.

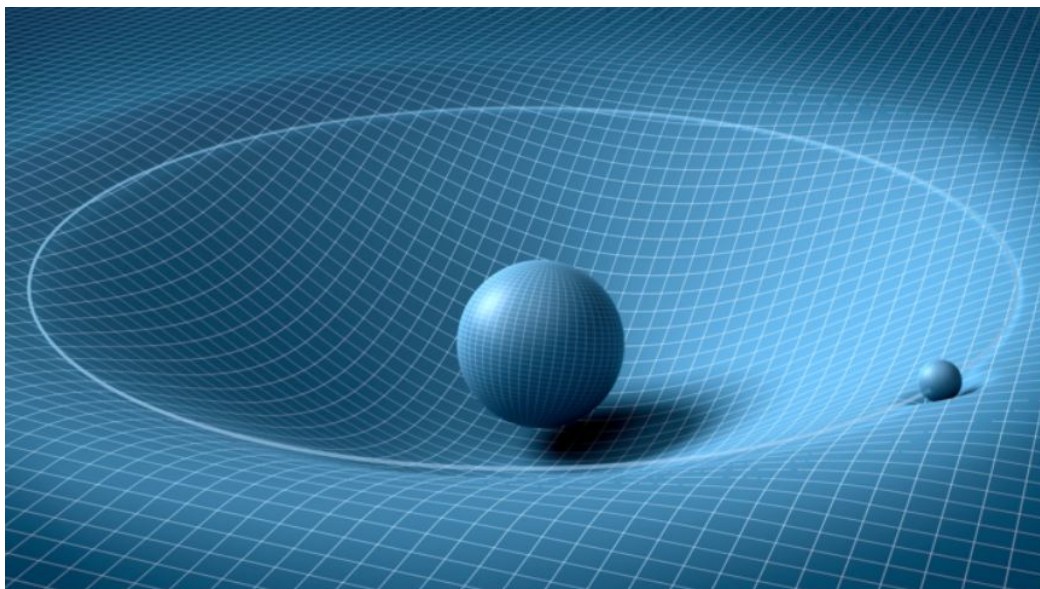

Figure 1 – Popularization of how a space “distortion” determines the attractive gravitational “force”. Source: Getty Images.

### 3. Possible spatial distortions that determine the “forces”

In the popularization of how a space “distortion” determines the attractive gravitational “force”, it is common the representation of the space, simplified to only two dimensions, as a plane and the distortions caused by the “masses” as hollows in this plane. As a result of these hollows, a smaller



“mass” (which determines a smaller hollow) is “attracted” by the greater hollow caused by a bigger “mass” (Figs. 1 and 2).

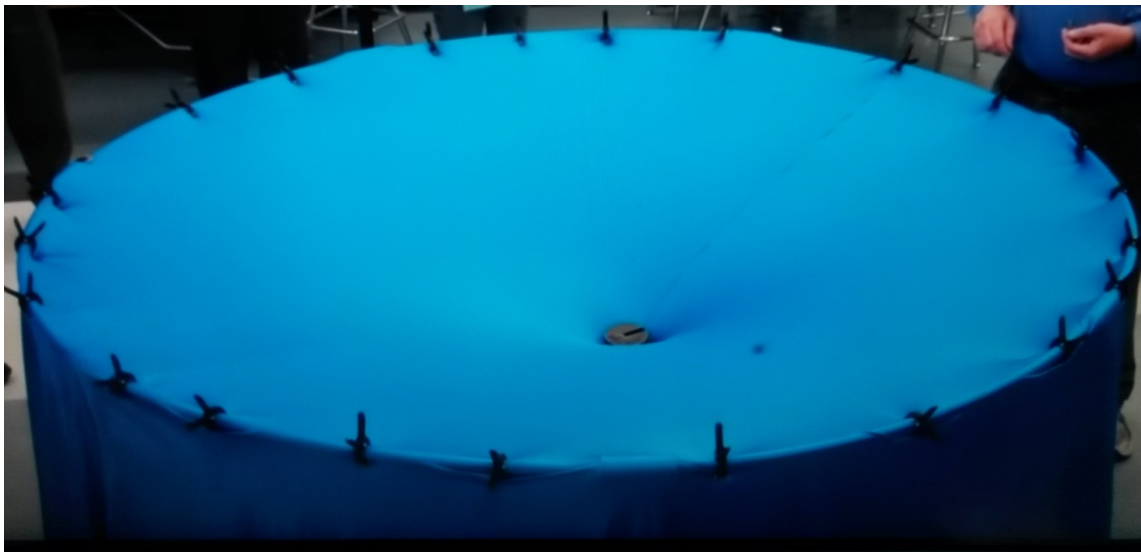

Figure 2 – The same. Source: <https://thekidshouldseethis.com/post/69092575516> (accessed on September 2021).

This kind of explanation is misleading. In fact, in the didactic examples, the smaller mass moves in the direction of the bigger mass due to the effect of the gravity that the example would like to explain. Moreover, if the space is flat without the presence of a “mass” and the “mass” determines the formation of a hollow, the lines deflected towards the “mass” are geometrically longer and so, defining a geodesic as the shorter line connecting two points, do not constitute geodesics. A different interpretation of space distortion determined by a mass is to conceive this distortion as a space “thickening” that would cause a deviation of the “spatial lines” towards the mass (Figs. 3 and 4).

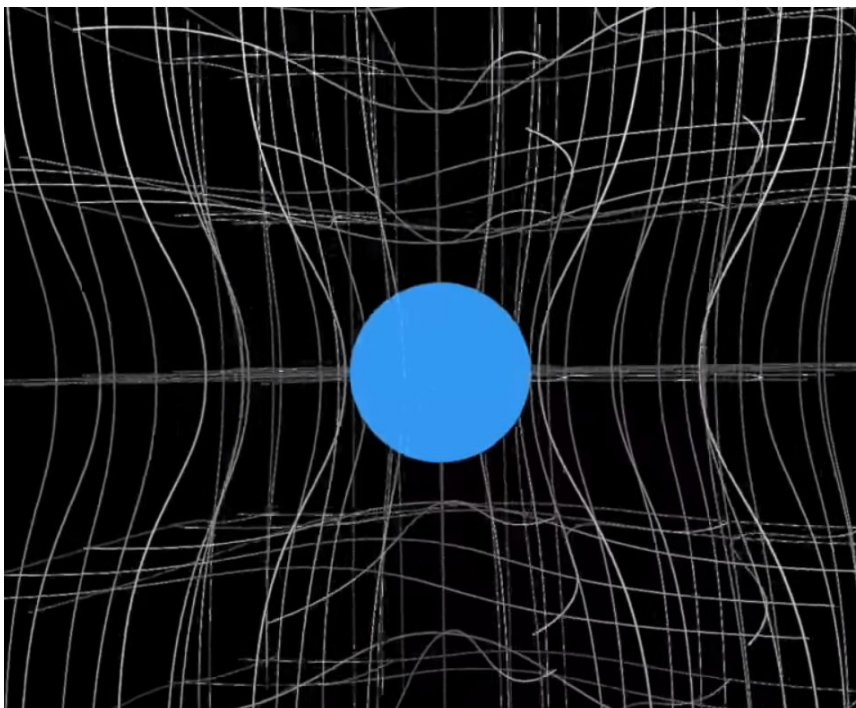

Figure 3 – Another popularization of how a space “distortion” determines the attractive gravitational “force”. Source: <https://www.youtube.com/watch?v=-m3SddsTSAY> (accessed on September 2021).

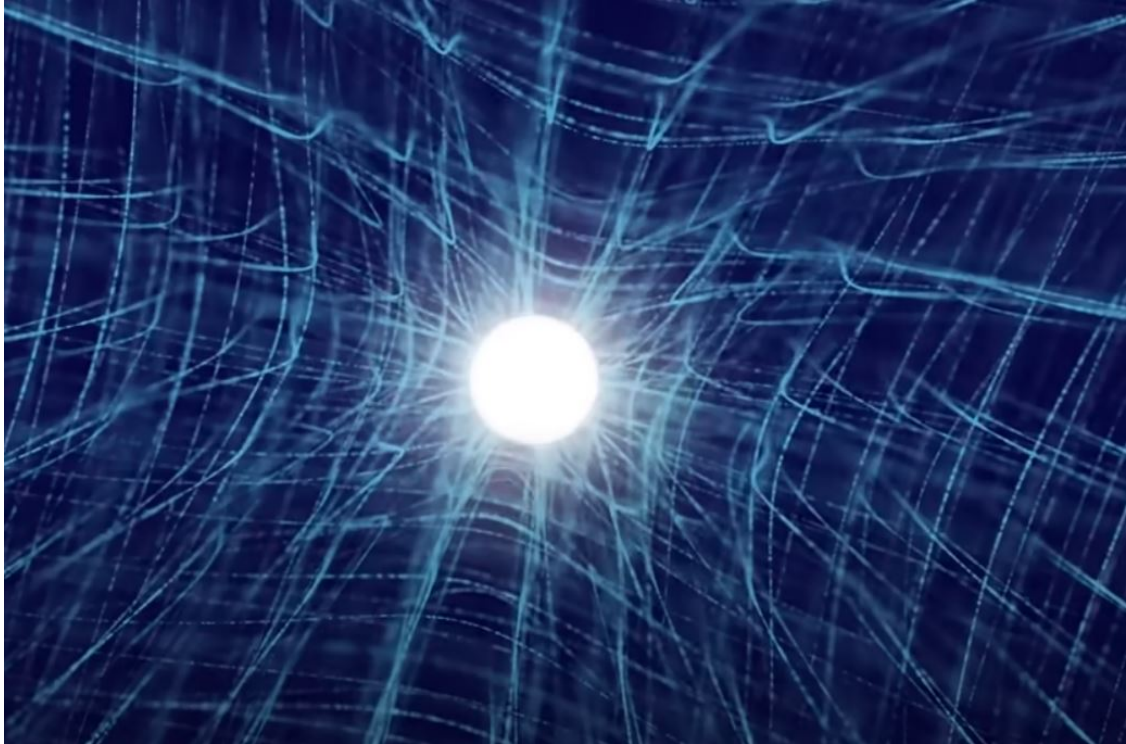

Figure 4 – The same. Source: <https://www.youtube.com/watch?v=wrwgIjBUYVc> (accessed on September 2021).

If this explanation were valid, we could hypothesize:

- space thickening -> deviation of the spatial lines towards the mass (“attraction”);
- space rarefaction -> deviation of the spatial lines away from the mass (“repulsion”).

However, we would have some big contradictions:

- 1) if the attraction between two masses is caused by space thickenings, how would the hypothetical attraction between two anti-masses (proposed by Villata [Villata 2011]) be explained? By supposing that the attraction in this case too is caused by space thickenings, then we should have also attraction between masses and anti-masses, in contrast to the repulsion proposed by Villata [Villata 2011];
- 2) for electrical phenomena, if the repulsion between two positive electric charges is caused by space rarefaction determined by each charge, and similarly for the repulsion between two negative electric charges, we should also have repulsion between electric charges of opposite sign, which is not true;
- 3) the deviations of the “spatial lines” in the case of space thickenings determine an elongation of these lines and so do not constitute geodesics. Consequently, we should have a repulsion and not an attraction. On the contrary, in the case of space rarefaction, the warped spatial lines are longer and the geodesics are those that go towards the masses. Consequently, we should have an attraction and not a repulsion.

In short, both didactic representations often used to describe space distortions as cause of the deviations that constitute gravitation do not appear coherent and logical for this purpose. They fall into obvious contradictions when used to explain the attraction between anti-masses and the repulsion between masses and anti-masses hypothesized by Villata. There are analogous contradictions if we want to explain in this way the repulsions between electric charges of the same sign and the attraction between electric charges of opposite sign.

However, any hypothetical solution that could be proposed should at least be compatible with the other fundamental questions mentioned in the premise and, indeed, should implicitly and easily lead to formulating explanations for these questions as well.

At this point, for a plausible explanation it is perhaps necessary to abandon the postulate that the space is flat and that a “mass” determines a curvature of space. Let’s start instead from the opposite postulate, i.e., that space is curved and a “mass” determines a flattening of the curvature.

The idea of a “curved” space is counterintuitive, as it is not part of our perception (s. Appendix 2), but this idea is at the root of general relativity.

Now, let us consider a two-dimensional space with positive curvature for both dimensions, that is, as mentioned in the Appendix 2, a sphere seen from the outside. If a “mass” has somehow the power to flatten the curvature in the surrounding area (in any case, without reversing the curvature!), the lines that come closer to the mass are shorter than those proceeding in rectilinear way. So, the lines that are closer to the mass are geodesics and this would explain why there is a deviation towards the mass, which is what we perceive and describe as gravitational force. But, explaining in the same way the hypothetical attraction between two anti-masses proposed by Villata, how would we explain the hypothetical repulsion between masses and anti-masses also proposed by Villata? In fact, if the “attractive” mechanism is identical for masses and anti-masses, we should also have an attraction between masses and anti-masses, which is the opposite of what Villata proposes.

Moreover, we could hypothesize that the repulsion between two positive electric charges is caused by accentuations of the curvature, i.e, a bulge on the spherical surface, so that the lines passing farther from the mass are shorter than those passing closer to the mass, so constituting geodesics and explaining the repulsion between two positive electric charges. The same could be hypothesized for two negative charges. However, if the mechanism is the same, there would be a repulsion even between charges of opposite sign, which is not true.

Consequently, the proposed mechanism could justify the attraction between two masses, or two anti-masses, and the repulsion between electric charge of the same sign while it is unsatisfactory and contradictory for the other phenomena proposed or reported.

Furthermore, how is it possible that, at the same time, space distortions can cause convergent and divergent deviations according to the combinations of masses/anti-masses, of positive and negative electric charges, etc.?

Perhaps some fundamental postulate is false.

In the classical pre-Einsteinian conception, we have the three spatial dimensions - inconceivable separately – plus the time, which was not understood as a dimension but as something completely different (three-dimensional hypothesis).

In Einstein’s proposal, the three spatial dimensions and the time constitute a single four-dimensional whole that cannot be conceived with the separation between space (understood as tridimensional) and time (four-dimensional hypothesis). As a likely implicit condition of his proposal, these dimensions in the absence of “masses” are considered as flat while the presence of “masses” determines curvatures that originate what we interpret as “gravitational force”. It should be noted that in 1916, the year in which general relativity was formulated [Einstein 1916], there was no knowledge of the expansion of the universe, proposed by Lemaître eleven years later [Lemaître 1927], and of what would later be called the Big Bang. This conception suggests that the universe was born from an infinitesimal primordial bubble which then expanded like a rubber balloon that inflates evenly in all its parts. An important implication is that Newtonian or Spatial dimensions, and presumably any other possible dimension, are curved, in contradiction with Einstein’s aforementioned condition of the flat dimensions, which was implicit in a conception proposed when the expansion of the universe was unknown. Therefore:

- the equations of general relativity should be adapted to a primary condition in which the dimensions are curved without “masses” while they tend to flatten as the presence of “masses” increases;

- the Einsteinian equations predict that the curvature of the dimensions increases without limits in proportion to the increase of the masses that determine the curvature. Conversely, if the masses flatten a pre-existing curvature, they cannot flatten it beyond the point where there is a maximum flattening.

So, as an alternative assumption in accordance with the concept of an expanding universe, it is necessary to consider that the spatial dimensions are curved in the absence of “masses” and that any “mass” determines a flattening of the curvature, originating what we interpret as “gravitational force”. At the same time, a bulge in the curvature could explain the repulsion between electrical charges of the same sign. However, this explanation cannot justify the contemporary existence of gravitational attraction between two masses (or two anti-masses) and the repulsion between masses and anti-masses, as well as the opposite phenomena between electrically charged bodies of the same or opposite sign.

To solve these contradictions, first of all it appears essential to presuppose the coexistence of several dimensions in order to explain the coexistence of several types of “attractions” and “repulsions” (gravitational, electrical, and of other types not yet mentioned).

Now, leaving aside the three-dimensional or classical hypothesis and the four-dimensional or Einsteinian hypothesis, let us postulate that there are infinite dimensions, each with its own curvature. All dimensions being curved are unlimited and, without any term of comparison outside of these dimensions, are infinite too. However, in the comparison between any two or more dimensions, there is always a finite relationship between such dimensions (except in the case where one of the two dimensions - if it exists - has zero curvature).

Then suppose that there are infinite subsets of these dimensions, each with a finite number of such dimensions, and that our universe is one of such subsets. Each subset is defined as a sub-universe and not as a local universe because there is no distinct “place” for any subset of dimensions or for any dimension.

If for each dimension we accept the “symmetry postulate”, that is to say that for each dimension there is no difference between its two possible directions, this implies that all dimensions are orthogonal to each other. In fact, even if only one dimension were not orthogonal to all the other dimensions, for the other dimensions there would be a difference between the two directions (Fig. 5).

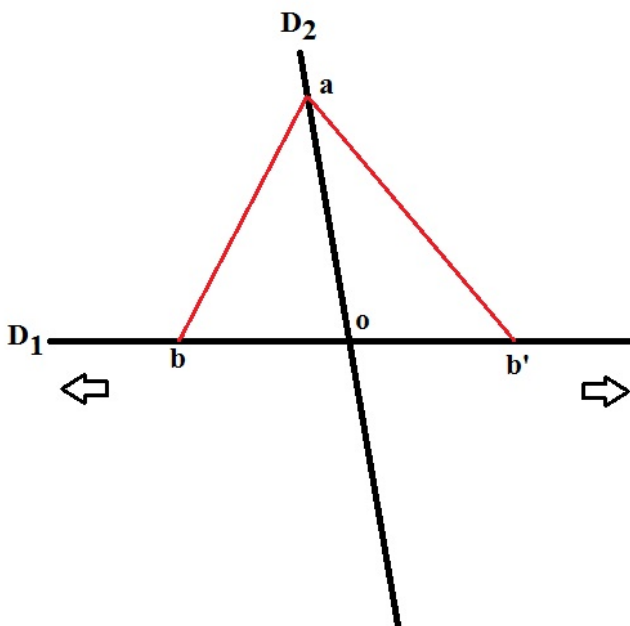

Figure 5 –  $D_1$  and  $D_2$  are two dimensions. If the two dimensions are not orthogonal, considering any point on  $D_2$  ( $a$ ) and two points on  $D_1$  ( $b$  and  $b'$ ) equidistant from the crossing point with  $D_2$  ( $o$ ), the distances  $ab$  and  $ab'$  are different and therefore there is difference between the two directions on  $D_1$  (indicated by the arrows). Similarly, it can be shown that there is a difference between two directions on  $D_2$ . With the same reasoning, if there are two or more orthogonal dimensions, any further non-orthogonal dimension determines a difference between the two directions of any dimension.

All possible one-dimensional spaces are described schematically in Fig. 6.

In this image:

- spaces with positive curvature are drawn as circles seen from the outside (upper part of the figure), and the radii have a positive value;
- spaces with negative curvature are drawn as circles seen from the inside (lower part of the figure) and the radii have a negative value;
- spaces with zero curvature (if existing) are represented by a straight horizontal line and can be considered as circles with radii of infinite length.

The ranges of values for the curvature of all possible dimensions are indicated in Table 1:

Table 1

$1/R$	$R$	Description
$<+\infty$ and $>0$	$>0$ and $<+\infty$	positive curvature
$0$	$+\infty$ or $-\infty$	zero curvature
$>-\infty$ and $<0$	$<0$ and $>-\infty$	negative curvature

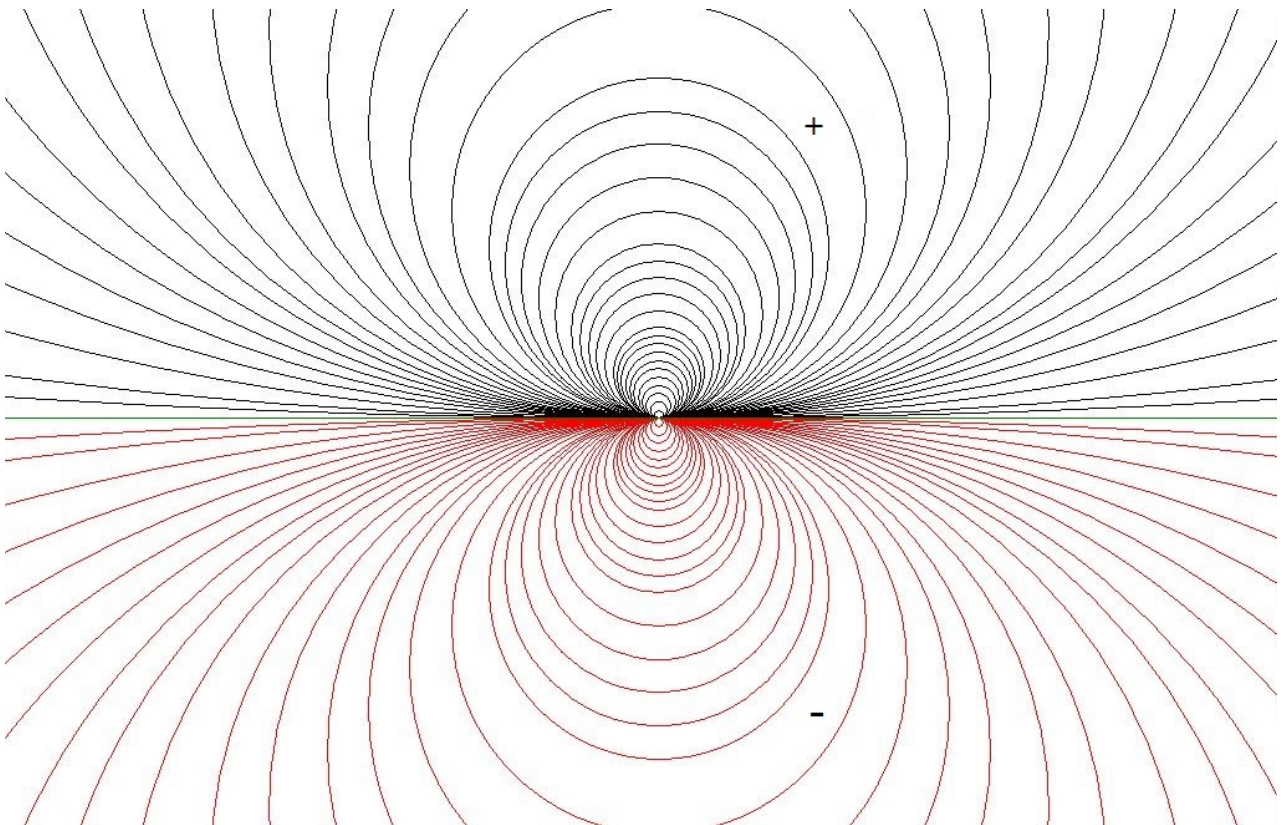

Figure 6 - Scheme of all possible one-dimensional spaces. In the upper part, spaces with positive curvature ( $1/R>0$ ); in the lower part, spaces with negative curvature ( $1/R<0$ ). The straight line represents any one-dimensional space with zero curvature ( $1/R=0$ ).

Referring to any one-dimensional space with non-zero curvature, and therefore describable as a circle, we define “flattening” any reduction of the curvature of a segment of the circumference directed from the circumference towards the centre.

In the surfaces with positive curvature, being the radius of positive value, there is a reduction in the distances between the centre of the curvature and the points in the area where there is the flattening. So, the flattened area constitutes a hollow.

In the surfaces with negative curvature, being the radius of negative value, there is an increase in the distances between the centre of the curvature and the points in the area where there is the flattening. So, the flattening area constitutes a bulge seen from the inside (Fig. 7).

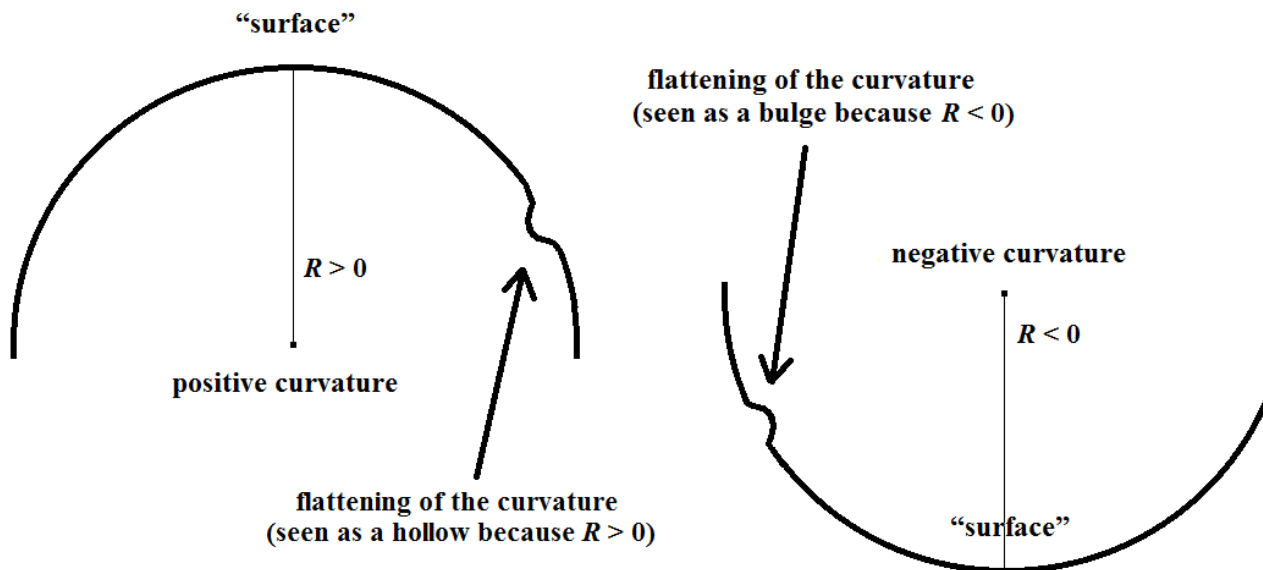

Figure 7 - "Surface" and "flattening" of the curvature in the case of dimensions with positive ( $R > 0$ ) or negative ( $R < 0$ ) curvature. For a better readability of the scheme, any flattening is strongly exaggerated (curvature should never be inverted!), becoming a hollow (if  $R > 0$ ) or a bulge (if  $R < 0$ ).

Now, let us consider a two-dimensional space of which one dimension is curved and the other has zero (or almost zero) curvature. It may be represented as the lateral surface of a regular cylinder.

For a curved surface, it is here defined as "geodesic" the line joining two points A and B that has the minimum area subtended by the line in respect of the underlying part of the cylinder axis. It should be remembered that if the curvature is positive all the radii that go from the cylinder axis to the surface have a positive value and therefore the area value is always positive. Conversely, if the curvature is negative, all the radii have a negative value and therefore the area value is always negative.

Consequently, if the curvature is positive a flattening reduces the value of the underlying area, while if the curvature is negative a flattening increases it. With this premise, with regard to the geodesics:

- on a surface with positive curvature the geodesic connecting two points tends to deviate towards a flattening (which in this case is a hollow);
- on a surface with negative curvature, the geodesic tends to move away from the flattening (which in this case is a bulge).

In a space having all dimensions with zero curvature (a Euclidean space if there are three dimensions), a flattening is impossible, as all the points are equally distant from the centre placed at infinity, and the geodesics are always the straight lines that joins two points.

Now, let us also imagine that a flattening in the curved dimension is determined by the double oscillation of a segment of this dimension. The double oscillation, if asynchronous, determines a rotation of the segment that can have only two directions of rotation (clockwise or counterclockwise) (Fig. 8).

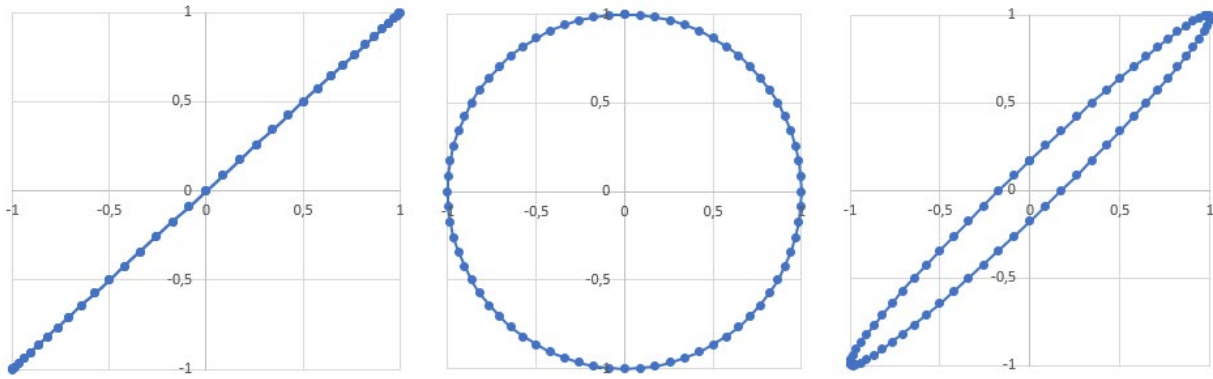

Figure 8 – A double oscillation seen from the front. The values of the sine of a point on the two curves are reported. Left: the two oscillations are synchronous; center: the two oscillations are out of phase by  $90^\circ$ ; right: the two oscillations are out of phase by  $10^\circ$ .

Let us consider two cases:

- In the first case, there is a two-dimensional space (one dimension with positive curvature and the other with zero curvature) graphically represented as the outer surface of a cylinder (upper part of Fig. 9). On the dimension with positive curvature, we put a greater flattening, drawn as a hollow projected towards the inside of the cylinder (in the image, the hollow is disproportionate as the curvature should never reverse), and a much smaller flattening (not drawn). Since the curvature is positive, the flattening causes deviations of the geodesics toward it.

If the two flattening have the same rotation (both positive or negative), it is easy to see that the geodesic describing the movement of the smaller flattening (while this runs along the direction of the dimension with zero curvature; vertical direction in the figure) moves towards the greater flattening both if the flattening go downwards (A in the figure) and if the flattening go upwards (A' in the figure). For a better readability of the scheme, a strong difference between the areas of the two flattening has been supposed, but the reasoning is analogous whatever are the values of the areas of the two flattening, stressing that in any case the two geodesics tend to converge.

On the contrary, if the two flattening have opposite rotations (one defined as positive and the other negative), as the oscillations determining the two flattening appear to run in the two opposite directions of the Time dimension (s. the discussion of paragraph (iv) below), the geodesics diverge in both directions along the vertical axis (B and B' in the figure).

- In the second case, there is a two-dimensional space (one dimension with a negative curvature and the other with zero curvature) graphically represented as the inner surface of a cylinder (lower part of Fig. 9). On the dimension with negative curvature, we put a greater flattening, drawn as a bulge projected towards the inside of the cylinder (in the image, the hollow is disproportionate as the curvature should never reverse) and a much smaller flattening (not drawn). Since the curvature is negative, the flattening causes deviations of the geodesics away from it.

If the two flattening have the same rotation (both positive or negative), it is easy to see that the geodesic describing the movement of the smaller flattening (running along the direction of the dimension with zero curvature; vertical direction in the figure) goes away from the greater flattening both if the flattening go downwards (C in the figure) and if the flattening go upwards (C' in the figure). For a better readability of the scheme, a strong difference between the areas of the two flattening has been supposed, but the reasoning is analogous whatever are the values of the areas of the two flattening, stressing that in any case the two geodesics tend to diverge.

On the contrary, if the two flattening have opposite rotations (one defined as positive and the other negative), as the oscillations determining the two flattening appear to run in the two opposite directions of the Time dimension (s. the discussion of paragraph (iv) below), the geodesics converge in both directions along the vertical axis (D and D' in the figure).

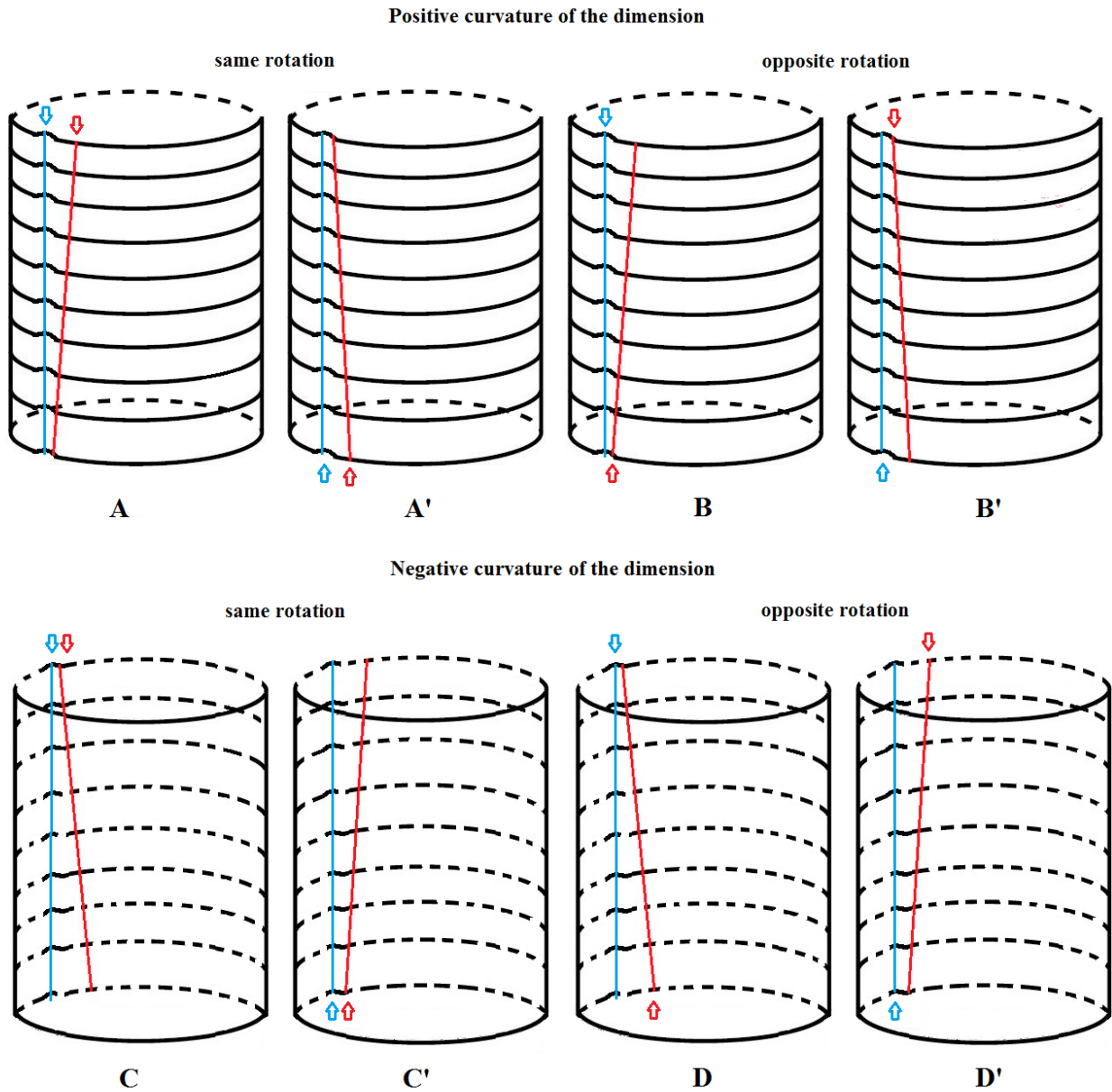

Figure 9 - Scheme of the displacements of two flattening according to the curvature of the space and the value (positive or negative) of the rotation. The greater flattening is indicated by a cyan arrow, while the smaller flattening by a red arrow. The displacement of the greater flattening is very small (not represented) and indicated by a cyan line while that of the smaller flattening is indicated by a red line. On the upper part, one dimension has positive curvature while the other has a zero curvature; on the lower part, one dimension has negative curvature while the other has a zero curvature; on the left (A, A', C, C') the rotations have the same values; on the right (B, B', D, D') the rotations have opposite values. For a better readability of the scheme, any flattening is strongly exaggerated becoming a marked hollow or bulge.

Now, the following definitions are proposed:

- i) the flattening are defined as “elementary particles” and the extent of the flattening as the measure of a property defined as “mass” or “electric charge” or otherwise according to the dimension;
- ii) the convergent or divergent deviations, are defined as “attractive forces” or “repulsive forces”, respectively;
- iii) the dimension with zero (or almost zero) curvature is defined as “Time” dimension (T)



iv) given two flattening with opposite rotations, the first that rotates clockwise toward a direction of T arbitrarily established will be defined as “particle” (or “particle+”) and the other as “antiparticle” (or “particle-”). This definition is inspired by the idea that particles and antiparticles are the same thing that goes in a time direction or in the opposite time direction, respectively, since the antiparticles reproduce the effects that would have if the particles went back in time [Randall 2005]. In fact: “J. Wheeler and R. Feynman proposed the idea that antiparticles are the particles moving backward in time. ... Positrons ... are antiparticles, they propagate from the future to the past.” [Teramoto 2015, pp. 40-41]. In fact, observing the motion of homogeneous points (for example, the apex) of the oscillations of a particle and its antiparticle, the two waves appear to run in the opposite directions of Time dimension (Fig. 10). This can lead to the misleading description of the antiparticle moving backward in the time, while it is more correct to say that particle and antiparticle differ in the direction of rotation of their oscillations. However, the first description is useful for understanding the attraction or repulsion between a particle and its antiparticle.

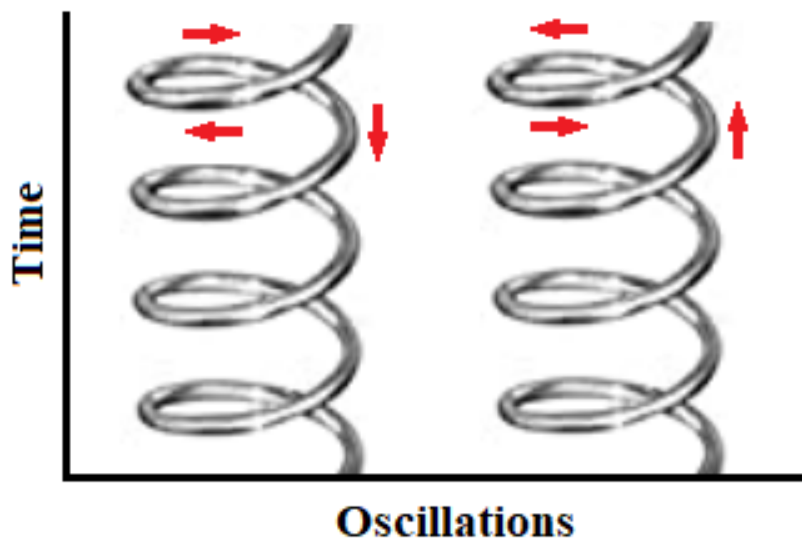

Figure 10 – On the left: the motion of the apex of a double oscillation for a “particle”; on the right: the same for an “antiparticle”.

The three possible types of dimensions and the deviations (“attractions” or “repulsions”) caused by “particles” / “antiparticles” are summarized in Fig. 11.

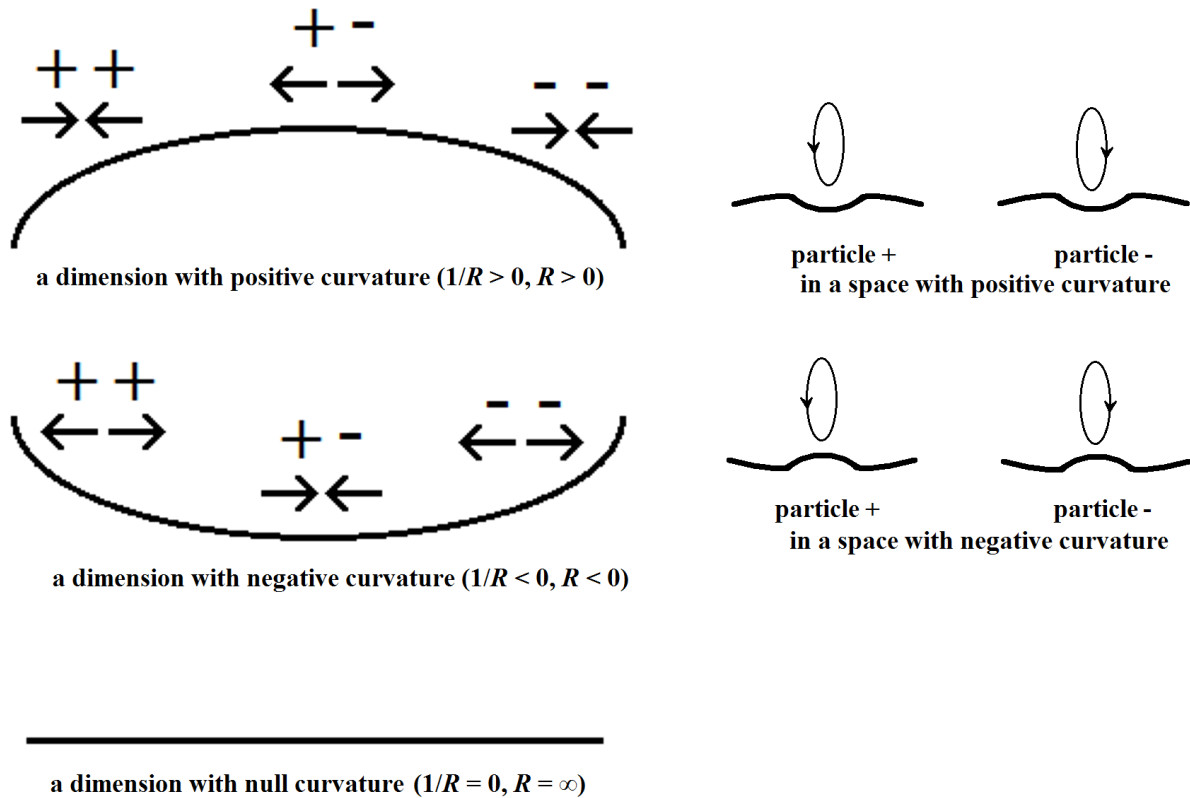

Figure 11 - The three possible types of dimensions. The “particles” are represented with the sign “+” or with the sign “-” depending on whether they have clockwise or counter-clockwise rotation. The “forces”, “attractive” or “repulsive”, are represented by convergent or divergent arrows, respectively.

Although these concepts and schemes might seem sterile abstractions, they have an interesting correspondence with real data. The three ordinary spatial dimensions together with the time dimension could be interpreted as three dimensions with equal positive curvature, defined as “Spatial” or “Newtonians” dimensions, together with a dimension with zero (or almost zero) curvature, defined as “Time” dimension. In each of the three “Spatial” dimensions, the “particles+” would attract each other (“force of gravity”), similarly the “antiparticles” (“particles-”) would attract each other, while a particle and an antiparticle would repel each other.

It is well known that general relativity excellently explains the so-called force of gravity as an effect of spatial distortions. Regarding the attraction between antiparticles (antimatter) and the repulsion between particles (matter) and antiparticles (antimatter): “... *gravitational behavior of antimatter is still unknown. While we may be confident that antimatter is self-attractive, the interaction between matter and antimatter might be either attractive or repulsive. We investigate this issue on theoretical grounds. Starting from the CPT invariance of physical laws, we transform matter into antimatter in the equations of both electrodynamics and gravitation. In the former case, the result is the well-known change of sign of the electric charge. In the latter, we find that the gravitational interaction between matter and antimatter is a mutual repulsion, i.e., antigravity appears as a prediction of general relativity when CPT is applied.*” [Villata 2011]

A different approach that also leads to the hypothesis of repulsion between matter and antimatter was proposed by Santilli a few years earlier [Santilli 1999]. Both theories are presented as extensions of the general relativity for which gravity is not a force (the deflection of the trajectory of a particle is determined by the curvature of the space-time) and on the idea that particles and antiparticles run in the two opposite directions of time. However, Villata predicts the repulsion between matter and antimatter by applying the C, P, and T-operators [Villata 2011, 2013, 2015], while Santilli predicts it

by applying isodual maps [Santilli 1999]. Some criticisms regarding the Villata's proposal were formulated by Cabbolet [Cabbolet 2011], but immediately dismissed by Villata [Villata 2011b].

A dimension with negative curvature, the "Electric" dimension, could explain the basic phenomena of electricity: (i) two particles with negative charge repel each other; (ii) two particles with positive charge, i.e., the electric antiparticles, also repel each other; (iii) two charges of opposite sign attract each other.

It is well known that the laws describing the attractions and repulsions between the electrical charges are similar to those describing the force of gravity:

$$\text{Newton's law of gravitation: } F_g = +G \cdot (m_1 \cdot m_2) / d^2 \quad (1)$$

$$\text{The same law integrated with Villata's hypothesis on antimatter: } F_g = +G \cdot (\pm m_1 \cdot \pm m_2) / d^2 \quad (2)$$

$$\text{Coulomb's law: } F_e = -k \cdot (\pm q_1 \cdot \pm q_2) / d^2 \quad (3)$$

As highlighted by Barrow [Barrow 2002], it is important to remember that Theodor Kaluza proposed as early as 1921 [Kaluza 1921] the hypothesis of electromagnetism as an analogue of gravity that propagated in an additional spatial dimension. In fact, Kaluza observed that with a fifth dimension Einstein's equations of general relativity would describe Maxwell's equations of electromagnetism [Green 2004, pp. 360-361].

At this point a question arises.

Is it possible to explain also the other known "forces" (strong force, weak force, forces acting on the so-called quark colors) as effects of further dimensions with positive or negative curvature? Moreover, is it possible to explain the structure of proton, neutron, electrons, quarks, etc. and of the reactions between particles, on the basis of this explanation?

Fig. 12 anticipates a possible interpretative scheme of some dimensions that could be hypothesized to explain these phenomena. These dimensions will be gradually introduced in the exposition.

These considerations can be summarized in a single formula, which might be defined as "general law of divergent/convergent deviations".

In any dimension X with radius  $R_x$  and so curvature equal to  $1/R_x$ , the degree of "convergent deviation" ("attractive force") or "divergent deviation" ("repulsive force") between two flattening ("masses" or other definitions) placed at a distance  $d_x$ , can be described by the following formula:

$$\Delta_X = \pm[\varphi_X(d_x) \cdot (\pm f_{X,1}) \cdot (\pm f_{X,2})] / d_x^2 \quad (4)$$

where (always in the dimension X):

$\Delta_X$  = deviation;  $f_{X,Y}$  = flattening Y;  $d_x$  = distance between the two flattening ( $f_{X,1}$  and  $f_{X,2}$ );  $\varphi_X(d_x)$  = a function of  $d_x$  and  $R_x$ .

This formula is similar to Newton's law, which describes the gravitational force, and to Coulomb's law, which describes the attraction or repulsion between electric charges, and, in fact, with some specifications and limits, it can be transformed into both formulas.

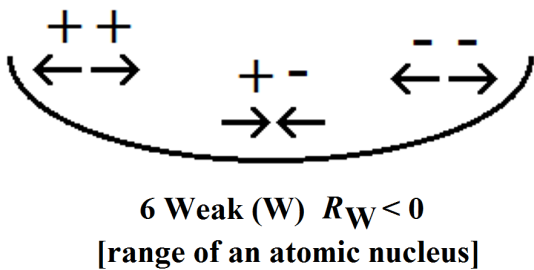
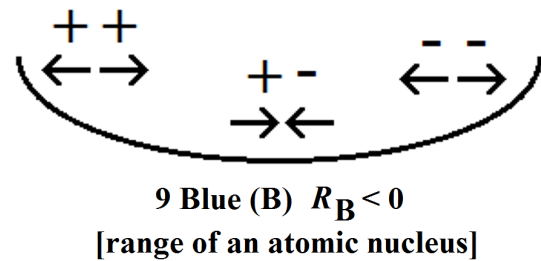
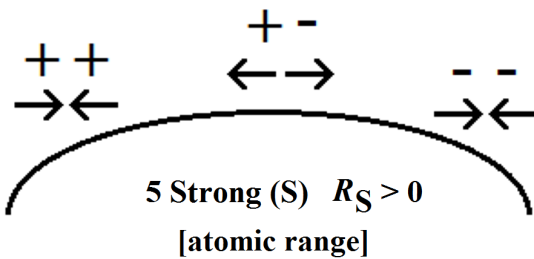
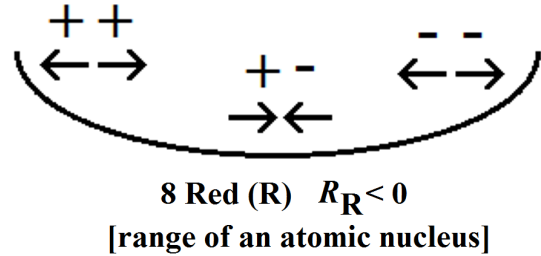
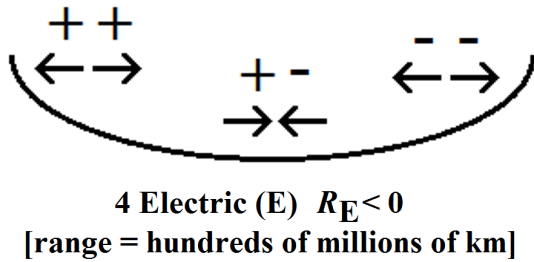
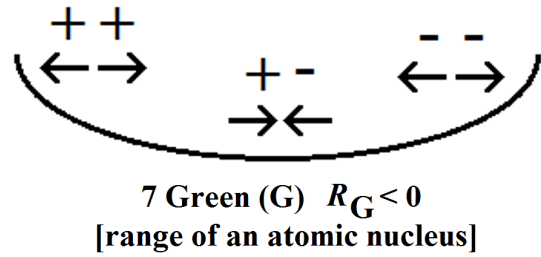
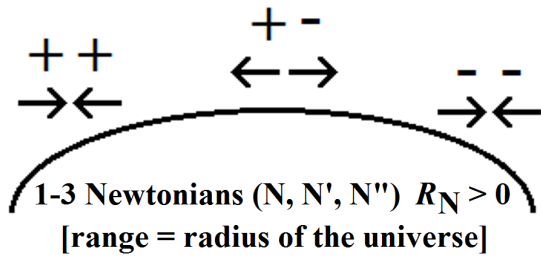

---

10 Time (T)  $\text{abs}[R_T] < R_L \text{ or } R_{L'}$

○

11 Planck (P)  $\text{abs}[R_P] = l_p/2\pi$

---

12 Entanglement 1 (L)  $\text{abs}[R_L] = / \approx \infty$

---

13 Entanglement 2 (L')  $\text{abs}[R_{L'}] = / \approx \infty$

Figure 12 - Possible dimensions of our sub-universe. In round brackets, the abbreviation of the name of the dimension. In square brackets, the range of the action in each dimension.

However, there are various and substantial differences:

---  $\Delta_X$

$\Delta$  means deviation (the Greek letter delta is used to avoid confusion with  $d$ , distance) and indicates the reciprocal deviations in the X dimension caused by two flattening of that dimension.  $\Delta$  may be measured in angles or as the ratio between  $\Delta_X$  and  $\Delta_{\text{time}}$ . It is not a force but, in mathematical terms, we can describe it as a “force” (without believing that a “force” exists!). Another possible mathematical description is that of the actions of a specific “field” (gravitational/electric/etc.; without believing that the field exists!). The sign  $\pm$  before  $\Delta_X$  indicates the curvature of the dimension X (+ = positive; - = negative).

---  $\pm f_{X,1}$  and  $\pm f_{X,2}$

$\pm f_{X,1}$  and  $\pm f_{X,2}$  indicate two flattening of the X dimension, each caused by the rotation of a segment of that dimension. The sign  $\pm$  indicates whether the rotation is positive (clockwise rotation), or negative (counter-clockwise rotation) and, by definition, a flattening with positive rotation is defined as “particle” or “particle+” and a flattening with negative rotation as “antiparticle” or “particle-”. It should be noted that the definition of clockwise or counter-clockwise rotation is arbitrary, and that the definition of flattening as “particles” does not mean that there are distinct entities defined as such. Depending on the type of the X dimension a “particle” can also be defined as “mass”, “electric charge”, or otherwise, but this should not be understood as the existence of distinct entities other than flattening of the X dimension.

---  $\varphi_X(d_X)$

$\varphi_X(d_X)$ , a parameter that is in function of  $d_X$  and is not a constant. It replaces the constants that there are in the equations of Newton and Coulomb. This could seem not corresponding with the empirical reality and somehow illogical. However, a simple argument shows that this is by no means illogical. Let us consider: (i) a curved dimension; (ii) a “particle” (i.e., a flattening) in the point A; (iii) two much lesser flattening equidistant from A and placed in opposite places (B and B'); (iv) the flattening in A exerts an “attraction” (or a “repulsion”) on the flattening in B and B'. According to the laws of Newton and Coulomb, attractions or repulsions act to an extent that decreases with the inverse of the square of the distance. However, at any distance these forces never become null as they are the function of a constant divided by the square of a finite value. Well, if the dimension is curved, as B and B' move away from A they eventually reach a point C at the antipodes of A (i.e., when  $d_X = \pi R_X$ ) in which the forces cannot have opposite directions at the same time and therefore must necessarily be null (Fig. 13).

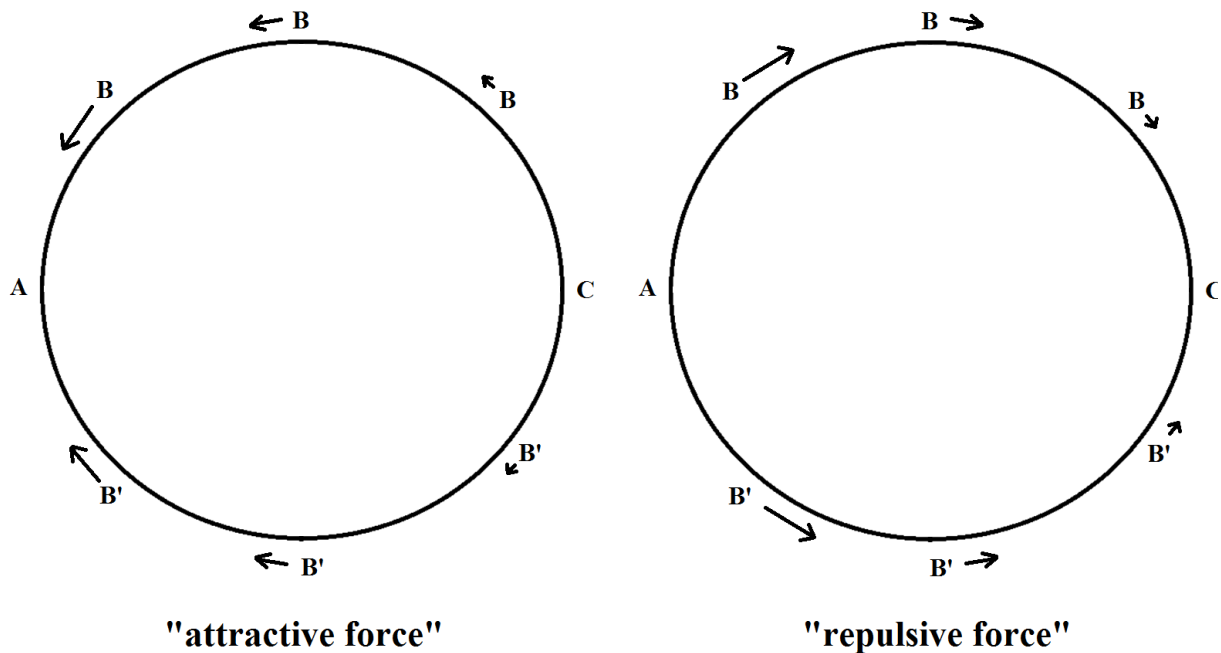

Figure 13 – In C, at the antipodes of A, the value of  $\varphi_X(d_X)$  [in this point it is  $\varphi_X(\pi R_X)$ ] must be necessarily null. If this value were different from 0, a “particle” in C should go simultaneously in two different directions, both in the case of an “attractive force” (on the left) and in the case of a “repulsive force” (on the right).

Consequently, the constants in the formulas of Newton and Coulomb, which by definition does not vary for any value of  $d_X$ , must be a function that varies with  $d_X$  and necessarily become null when the two flattening are at the antipodes.

For gravitational and electrical “forces”, it is very difficult or perhaps impossible to verify experimentally that they, as well as decreasing with the square of the distances, become null when  $d_X = \pi R_X$ .

So, the topic may seem of little interest and irrelevant value. However, if we apply the same general law to dimensions with very small  $R$  (for example within the range of an atom or of an atomic nucleus), there is the interesting prediction that “forces” as the strong force and the weak force, even if much stronger than gravitational force at atomic or nuclear distances, must be reduced in a proportion greater than the inverse of the square of the distances and must become null at distances within the range of an atom or of the nucleus of an atom, respectively. This would explain a known enormous contradiction: the gravitational “force”, which is very weak, still acts at distances of billions of light years, while the strong “force” and the weak “force”, which at atomic level are enormously stronger than the gravitational force, become irrelevant outside the atom and the nucleus, respectively.

---  $1/d_X^2$

The force of gravity between two masses is in relation with the square of the distance between the two masses. The usual justification, as explained by Green [Green 2004, pp. 396-397], is in terms of lines of a force field in a three-dimensional space: “... *the sun’s gravitational field lines ... have a density at a distance  $d$  that is inversely proportional to the area of an imaginary sphere of radius  $d$  ... an area which basic geometry shows to be proportional to  $d^2$ .*” Unlike that, in the interpretation proposed here of the “gravitational force” (and of any other “force”), it is the effect caused by the distortion of a one-dimensional space: 1) the distortion (and therefore the deviation of the geodesics) is inversely proportional to the distance from a flattening (i.e.,  $\propto f_X/d_X$ ); 2) the product of the attraction between two flattening is proportional to the deviations of the two geodesics and therefore proportional to the product of the two flattening and inversely proportional to the square of the distance between the two flattening, i.e.,  $\propto (f_{X,1}/d_X) \cdot (f_{X,2}/d_X) = \propto (f_{X,1} \cdot f_{X,2})/d_X^2$ .

In the case of three distinct “Spatial” dimensions (which we have supposed of equal positive curvature) it is necessary to sum of the vectors in the three Spatial dimensions and we will always have that the deviation is  $\propto (f_{X,1} \cdot f_{X,2})/d_X^2$ .

#### 4. Effects of the General Law of Divergent/Convergent Deviations in the comparison among dimensions with different curvature

Referring to different pairs of dimensions – the first, a curved dimension with radius= $R_y$ , and the second a dimension with zero (or almost zero) curvature -, which can be represented as the surface of a cylinder, the difference between the various cylinders can only be in the degree of curvature of the first dimension.

In the comparison between the effects on two different cylinders by possible flattening in the curved dimension, we must consider some parameters in any cylinder  $y$ :

- $z_y$  = in reference to the radius passing through the center point of the flattening  $z$ , the difference between the crossing point in the non-flattened curve and the crossing point in the flattening;
- $\text{abs}(z_y)$  = the absolute value of  $z_y$ ;
- $\%(z_y)$  = the relative value of  $z_y$  in relation to the radius of the curved dimension ( $=z_y/R_y$ );
- $\Delta_y$  = the deflection angle caused by the flattening.

With regard to the General Law, some considerations are immediately possible:

- (i) The law (including the function  $\varphi_X(d_X)$  within the formula) is the same for all cylinders as they are geometrically similar;
- (ii) If the two cylinders are identical ( $R_1=R_2$ ), the same values will always be obtained from the formula;
- (iii) If the two cylinders are different ( $R_1 \neq R_2$ ; and setting  $R_1 > R_2$ ), on the basis of simple geometric considerations,
  - if  $\%(z_1) = \%(z_2)$  (i.e.,  $z_1/R_1 = z_2/R_2$ ), we will have identical values of  $\Delta$ ;
  - if  $\%(z_y)$  is smaller in a cylinder (e.g.,  $z_1/R_1 < z_2/R_2$ ), we will have a smaller value of  $\Delta$  for that cylinder;
  - if  $\text{abs}(z_1) = \text{abs}(z_2)$ , as  $R_1 > R_2$  has been set, we will have  $\text{abs}(z_1)/R_1 < \text{abs}(z_2)/R_2$ , that is  $\%(z_1) < \%(z_2)$  and therefore  $\Delta_1 < \Delta_2$ .

The point (iii) is illustrated in Fig. 14.

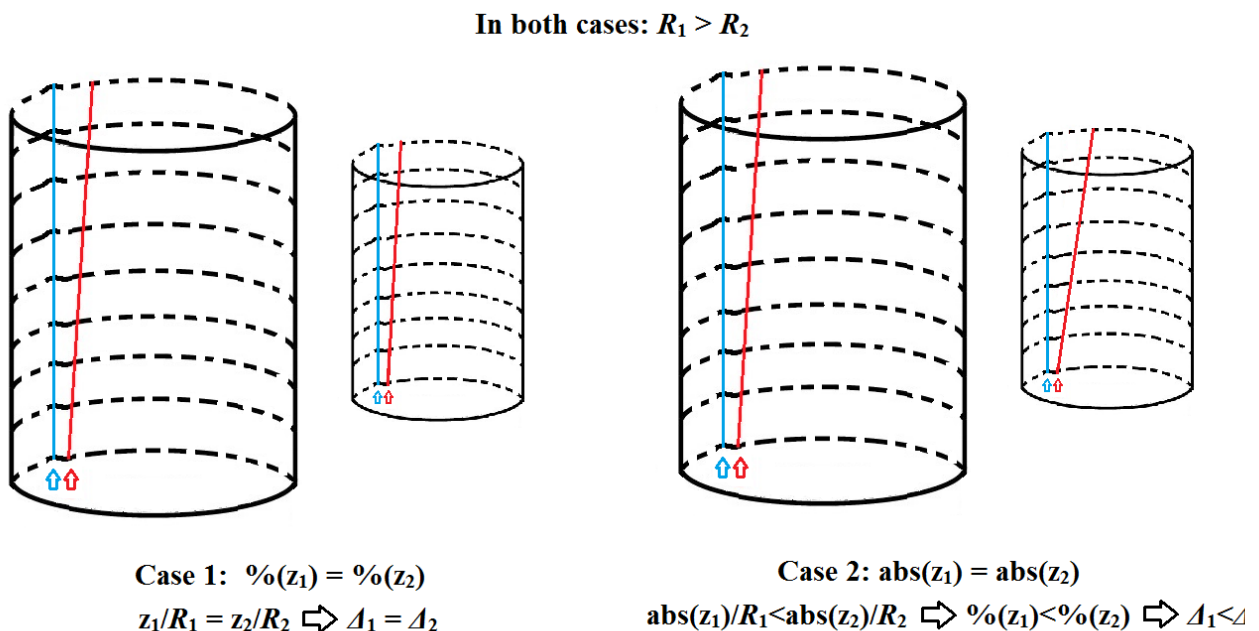

Figure 14 – In both cases the curved dimension has a negative curvature, the flattening have the same rotation, and  $R_1 > R_2$ . Case 1: The two flattening have the same percent value of  $z$ , i.e.,  $\%(z_1) = \%(z_2)$ , and so  $\Delta_1 = \Delta_2$ ; Case 2: The two flattening have the same absolute value, i.e.,  $\text{abs}(z_1) = \text{abs}(z_2)$ , and so:  $\text{abs}(z_1)/R_1 < \text{abs}(z_2)/R_2 \rightarrow \%(z_1) < \%(z_2) \rightarrow \Delta_1 < \Delta_2$ .

Now, let us consider two cases: in the first, the curved dimension has a very small radius ( $R_1$ ), within the range of an atomic nucleus, while in the second case there is a radius ( $R_2$ ) equal to that of our universe. The above tells us that in the case of two flattening with an equal absolute value, i.e.  $\text{abs}(z_1)=\text{abs}(z_2)$ , there will be a deviation (that is, a “force”) much greater in the first case than in the second case (i.e.,  $\Delta_1 \gg \Delta_2$ ). However, as  $\varphi_X(d_X)$  becomes null at a distance equal to or greater than  $\pi \cdot R_X$ , despite the great difference between the two “forces”, the greater one will be null beyond the small distance  $\pi \cdot R_1$  while the second, very weak, force will have an effect even at enormous distances ( $\pi \cdot R_2$  is extraordinarily huge!).

Considering the “strong” and the “weak” forces and the gravitational force, we can easily see the analogy between the characteristics of these real forces and those of the two hypothetical aforementioned forces.

## 5. Quantization of our sub-universe

It is well known that physical phenomena are quantized, that is, their parameters can only assume discrete values. There are numberless experimental works and many formulas that demonstrate or describe quantized phenomena [Sakurai and Napolitano 2020], but there is no explanation of why phenomena are quantized.

Now, let us hypothesize for our sub-universe a curved dimension, defined as “Planck dimension” or “P dimension”, with a very small circumference, e.g., with a radius,  $R_P$ , like or equal to Planck length ( $l_p = 1.616252E-35$  m), and, therefore, much smaller and with a curvature ( $1/R_P$ ) much greater than any other dimensions.

For this dimension, a hypothetical flattening equal in absolute value to a flattening of any other dimension, would cause deviations of the geodesics (“forces”) much greater than those caused in any other dimensions, but with no effect beyond Planck’s very small length.

Furthermore, it is difficult to imagine how any other dimension could cause a flattening in P dimension. A “force” determined by flattening in any other dimension would act on P dimension with an intensity comparable to that of an extremely rarefied gas on an ultra-strong metallic ball, that is to say, with null effect.

Since P dimension, according to its definition, exists in each point of any dimension of our sub-universe, any distortion (linear, two-dimensional, three-dimensional, etc.) of any dimension or group of dimensions could not be inferior to  $R_P$ , or to a circumference equal to  $2\pi \cdot R_P$ , or to a sphere of radius equal to  $R_P$ , and so on. This is because a distortion below this limit would determine a flattening in P dimension, which appears unlikely.

Moreover, any distortion above this lower limit must be an exact multiple of this minimum measure. In fact, if a distortion was equal to  $z$  times the minimum measure, with  $z$  a not integer number and equal to an integer number ( $n$ ) plus a fractional part, by subtracting  $n$  minimum parts from  $z$  we would have as residual portion a part that is a fraction of the minimum measure, which is not possible.

All this implies that any phenomenon in our sub-universe, for any dimension, the Time dimension (T) included, or for any group of dimensions, is subordinated in quantitative terms to the curvature of P dimension and therefore all the phenomena must be quantized in relation to  $R_P$ .

As visual representations, let us imagine:

- a group of two dimensions, the P dimension and any other dimension with a much lower curvature. These two dimensions could be seen as a very long and extremely thin tube. We can imagine bending the tube in infinite ways but never so as to reduce its section because this would mean a squeezing of the P dimension;
- a group of three dimensions, the P dimension and two other dimensions with a much lower curvature. It would be as a very thin sheet that we can fold in infinite ways without never getting areas smaller than the section of the P dimension because this would mean squeezing the P dimension;



--- the P dimension and a group of  $n$  dimensions with a much lower curvature. In each point of this multidimensional space there is the P dimension and so we can bend in infinite ways the multidimensional space but cannot get a multidimensional piece with any of its part smaller than P dimension.

About the origin of quantized phenomena, as underlined by Barrow [Barrow 2002], it is important to remember the proposal of Oskar Klein. He wrote to Niels Bohr [Klein 1926] suggesting that the origin of Planck's length should be searched in a fifth dimension that was extremely small and circular (with a circumference of about  $10^{-30}$  cm, i.e., something more than Planck length) and with a presence imperceptible because of this. According to this author, the constancy of fine structure that we see in three dimensions, i.e., the quantization of any phenomenon, derives from the size of this additional dimension. Klein's proposal was based on Kaluza's hypothesis that a fifth dimension could explain the phenomena of electromagnetism [Kaluza 1921] and for this reason the two proposals are known as *Kaluza-Klein theory* [Green 2004, p. 366]. However, it seems that these two authors did not realize that while to explain the quantization of phenomena an extremely small dimension was necessary, on the contrary, to explain the electromagnetic phenomena a further and much larger dimension was needed. (Moreover, further dimensions would be needed later to explain other phenomena such as weak force and strong force.) Perhaps due to this primary insufficiency, Kaluza's hypothesis, Klein's hypothesis, and their unification into a single hypothesis (*Kaluza-Klein theory*) soon showed insuperable contradictions and were considered theories without prospects, despite the efforts that were dedicated to them also by Einstein [Green 2004, p. 366]. Yet, despite this, Kaluza and Klein have the great merit of having indicated the need to search for the origin of electromagnetism and quantization of phenomena in the existence of further dimensions.

## 6. Model of the atom

On the basis of what has been said so far, and excluding for now the force of gravity that has negligible value in the atomic range, let us try to hypothesize how the structure of an atom can be interpreted.

We know several things:

- In an atom there is a certain number of positive charges (one for each proton, in units arbitrarily defined as equal to the charge of a proton). This number is equal to the number of negative charges present in the electrons (one for each electron, in units arbitrarily defined as equal to the charge of an electron). Positive charges repel each other because they would be flattening in a dimension with negative curvature (“Electrical dimension”, E). Likewise, we could explain the repulsion between negative charges, which are proposed as the antiparticles of the positive charges. The attraction between positive and negative charges is also explained because in a dimension with negative curvature, particles and antiparticles attract each other.
- The protons repel each other because their charges have the same positive sign, but an attractive “force” - determined by “particles”, present in both protons and neutrons, which would be flattening in a dimension with positive curvature defined as “Strong” (S) - would bind together protons and neutrons. In order for this force to keep the nucleus stable, it is necessary that the number of neutrons be equal (in the case of helium) or higher (all the other atoms) to the number of protons. A motivated exception is hydrogen in which there is only one proton and so the presence of neutrons is unnecessary.
- In order that neutrons do not merge with each other and likewise that protons do not merge with each other and that neutrons do not merge with protons, it is necessary to hypothesize the presence of another “force” - determined by “particles” that would be flattening in a dimension with negative curvature defined as “Weak” (W) - which would balance the attractive force of the strong force.
- The electrons repel each other (as they have the same charge) and are attracted to the nucleus (as the charges of electrons and protons are opposite). Since they do not fall toward the nucleus, there must be a force that rejects them. In addition, the electrons are kept distinct from each other (since they have the same charge) but do not disperse and therefore there must be a force that prevents this. The attractive force between the electrons and the repulsive force between electrons and nucleus could be explained by the presence of antiparticles of the Strong dimension, which attract each other among the electrons and are repelled by the particles of the strong force present in the nucleus.

These hypotheses are illustrated in the scheme of Fig. 15.

The empirical data give us more pieces of information that show a more complex reality.

In each proton or neutron there are some entities defined as quarks:

- In the proton, there are two quarks of a type defined as “up” (*u*), with a positive charge equal to  $2/3$  of that of the proton (i.e.,  $+2/3$ ), and a quark of a type defined as “down” (*d*), with a negative charge equal to  $1/3$  of that of the electron (i.e.,  $-1/3$ ). Therefore, the total electric charge is equal to:  $2/3+2/3-1/3 = +1$  (the opposite of an electronic charge);
- In the neutron, there is a quark of type up and two quarks of type down. Therefore, the total electric charge is equal to:  $2/3-1/3-1/3 = 0$ ;
- Each quark has a quality defined as “color”, which can be Red, Green or Blue. Moreover, in a proton, or in a neutron, there is only one quark of each of these three colors.

The existence of three types of color and the fact that there is no presence of colors of the same type in a single proton or neutron, induces to hypothesize the existence of three further dimensions with negative curvature, defined as “Red” (R), “Green” (G), and “Blue” (B), and therefore with particles of the same color that repel each other. Likewise, for each of these dimensions, the antiparticles should repel each other, while, on the contrary, a particle and its antiparticle should attract each other.

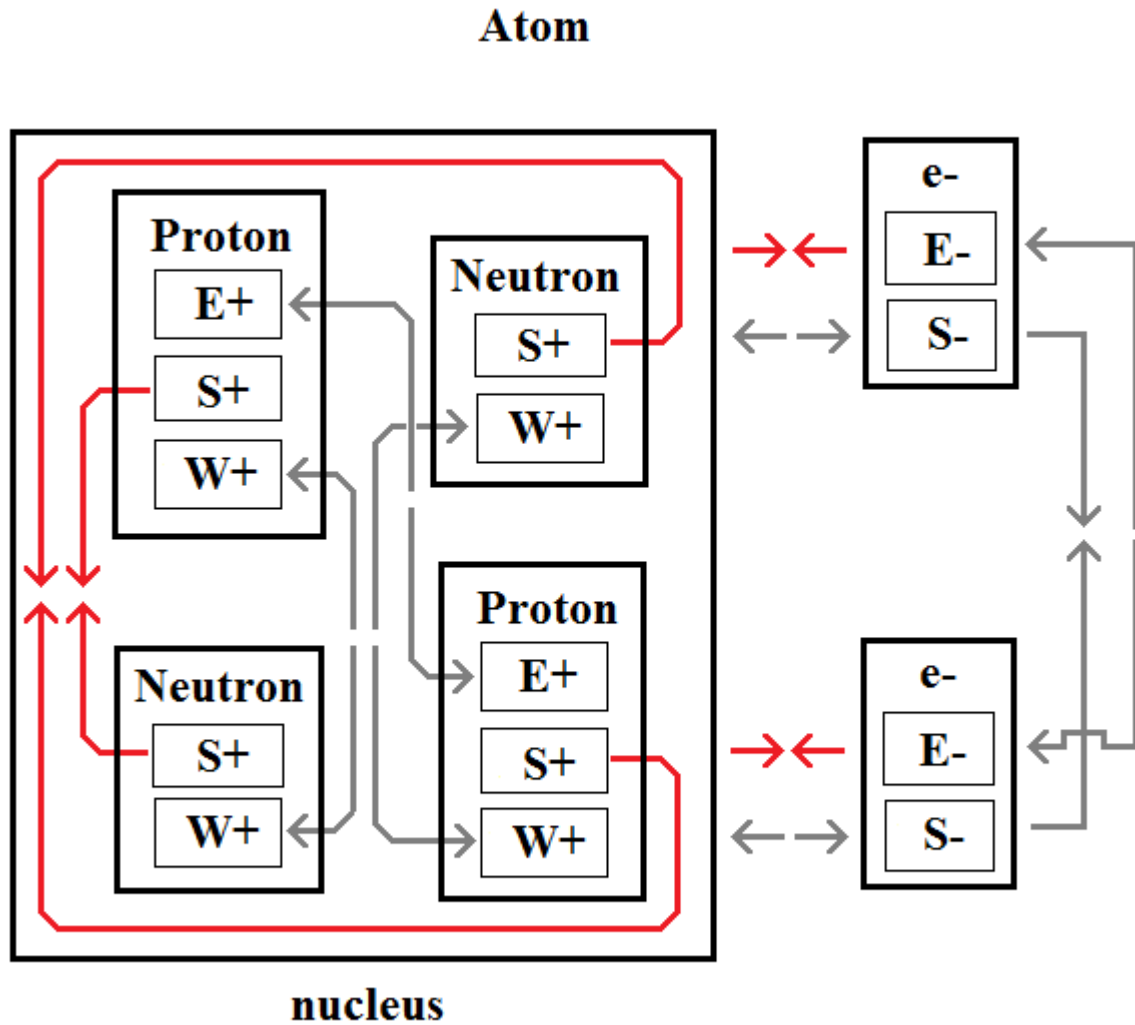

Figure 15 - General scheme of the atomic structure as hypothesized. E+ and E- = particle and antiparticle of the Electrical (E) dimension; S+ and S- = particle and antiparticle of the Strong (S) dimension; W+ and W- = particle and antiparticle of the Weak (W) dimension. Part of the attractions / repulsions are omitted to simplify the scheme.

Considering this, the aforementioned phenomena could be interpreted by the structures proposed in the schemes of Figs. 16 and 17 (model 1), or also with the structures proposed in the schemes of Figs. 18 and 19 (model 2). The difference between the two models is that in the quark up, for the model 1 there is only one W+ particle, while for the model 2 there are two W+ particles. The symbols W+ and W- represent flattening with opposite rotations in the “Weak” (W) dimension and must not be confused with the symbols representing the vector boson+ (W+) and the vector boson- (W-).

It should be noted that in both models, the electron (e-) is conceived as the set of three pairs of a single E- (negative charge or antiparticle of E+, in units of electric charge equal to one third of that of an electron, definable as tertiary charge) and a single S- (antiparticle of S+). Similarly, the positron (e+) is conceived as the set of three pairs {E+, S+}. This is quite different from the common representations of the electron as an isolated negative charge and of a positron as an isolated positive charge. However, this hypothetical interpretation is motivated by the aforementioned facts.

Two parallel questions:

- Why in the quarks there are at most two tertiary charges (2/3 of the charge of the electron or of the positron) and not a greater number?

- Why would the electron and positron consist of 3 tertiary negative/positive charges and not a different number?

Possible answers. The repulsive force of three tertiary charges (negative in the electron and positive in the positron) is sufficiently balanced by the attractive force of the three particles S (S<sup>-</sup> in the electron and S<sup>+</sup> in the positron). A larger number is perhaps not sufficiently balanced by the attractive charge of an equivalent number of S particles. With a smaller number there would be aggregation caused by the particles S. In the quarks and the anti-quarks, as there is also the repulsive force of the W<sup>+</sup> and W<sup>-</sup> particles, respectively, the maximum number of tertiary charges would be 2 and not 3. For the overall stability of the proton (and of the antiproton), in which there are 3 tertiary charges, see the next part.

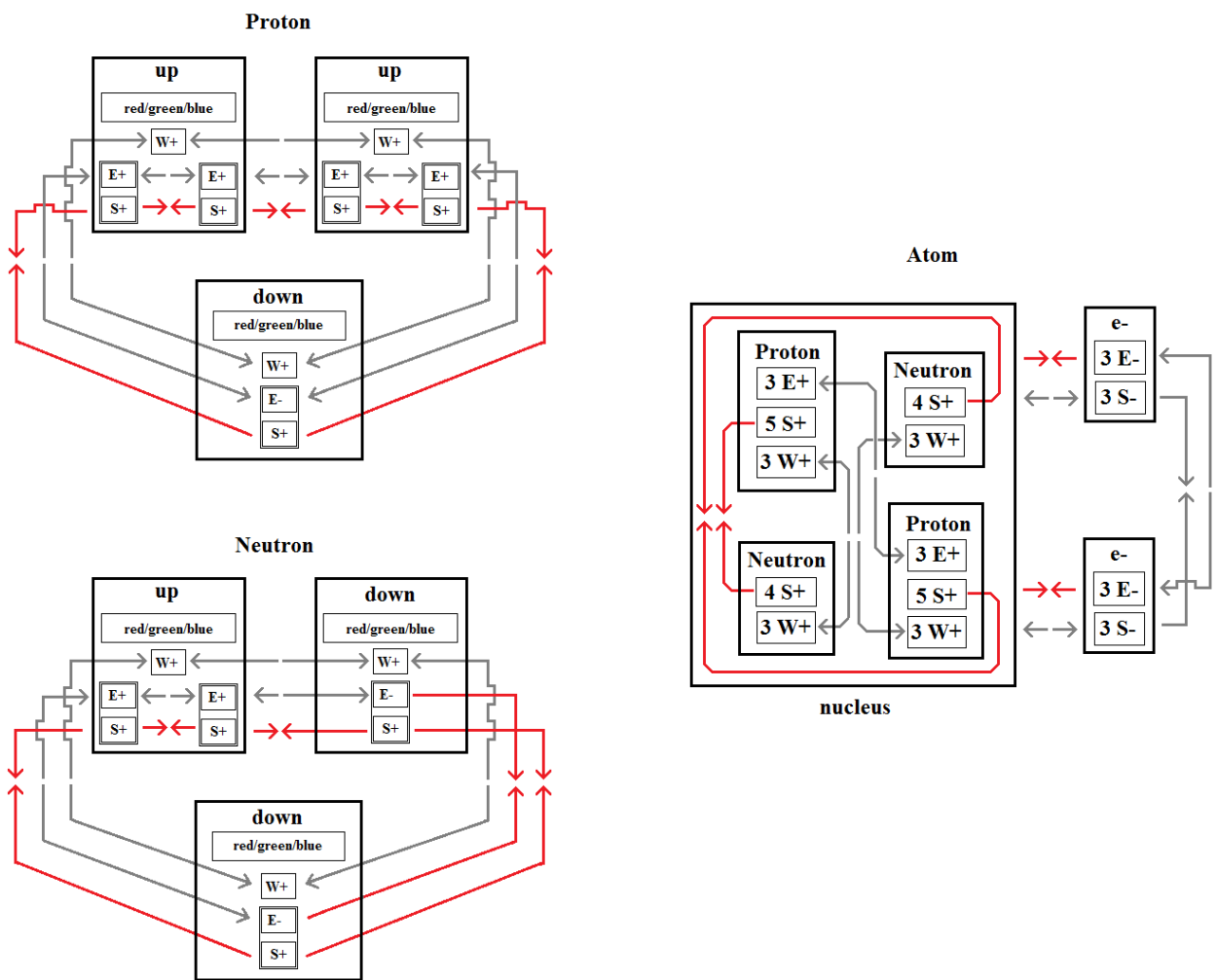

Figure 16 - Model 1, with a single W<sup>+</sup> particle in the quark up. Schemes of proton, neutron and atom. Part of the attractions / repulsions are omitted to simplify the scheme.

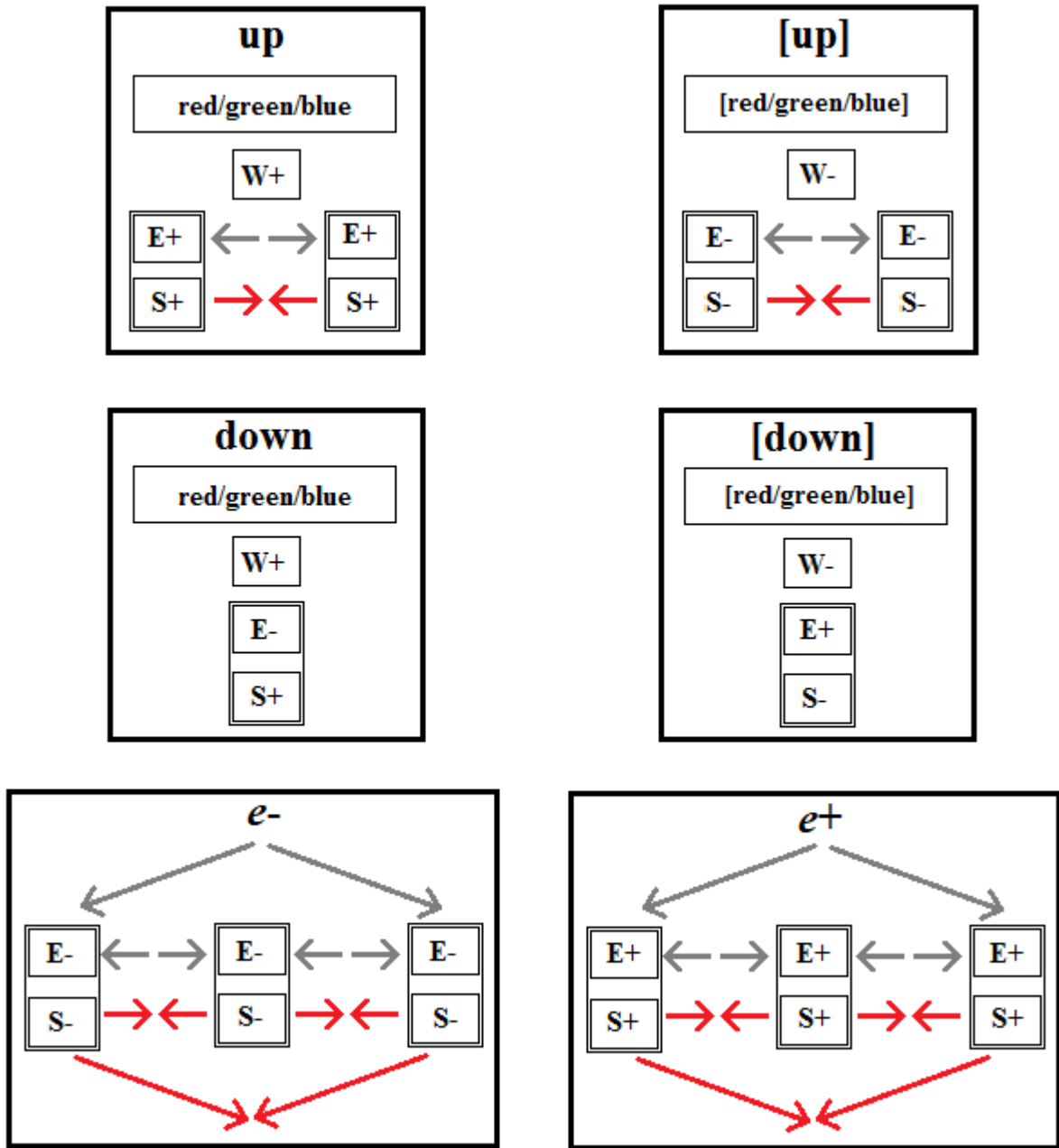

Figure 17 - Model 1, with a single  $W^+$  particle in the quark up. Schemes of the quark up, [up], down, [down], of the electron ( $e^-$ ) and of the positron ( $e^+$ ). Groupings of multiple particles that are commonly referred to as antiparticles are enclosed in square brackets. For example: anti-up = [up]. For uniformity of writing, the electron should be indicated with  $e$  and the positron with  $[e]$  as an alternative to the usual writings  $e^-$  and  $e^+$ .

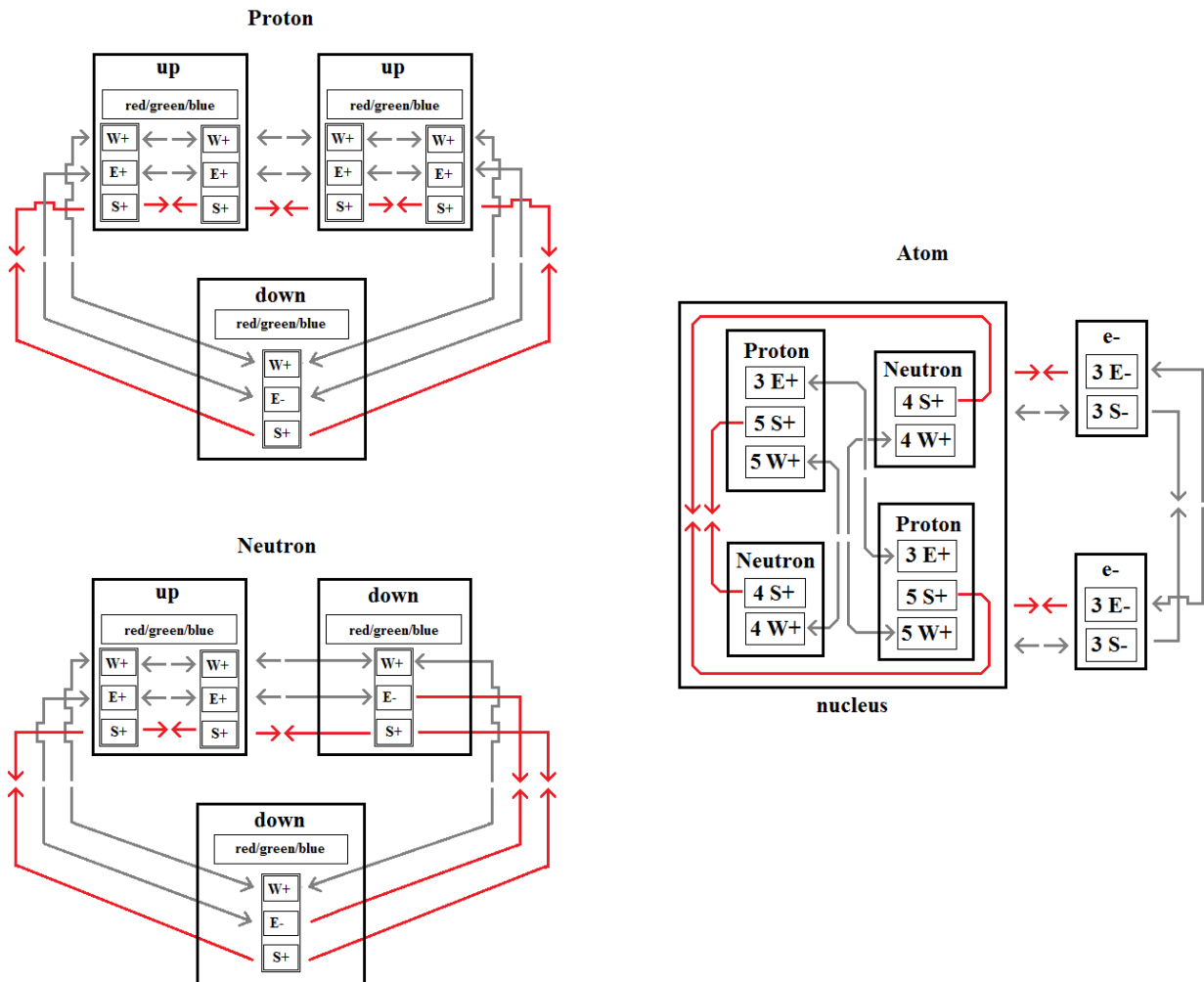

Figure 18 - Model 2, with two  $W^+$  particles in the quark up. Schemes of proton, neutron and atom. Part of the attractions / repulsions are omitted to simplify the scheme.

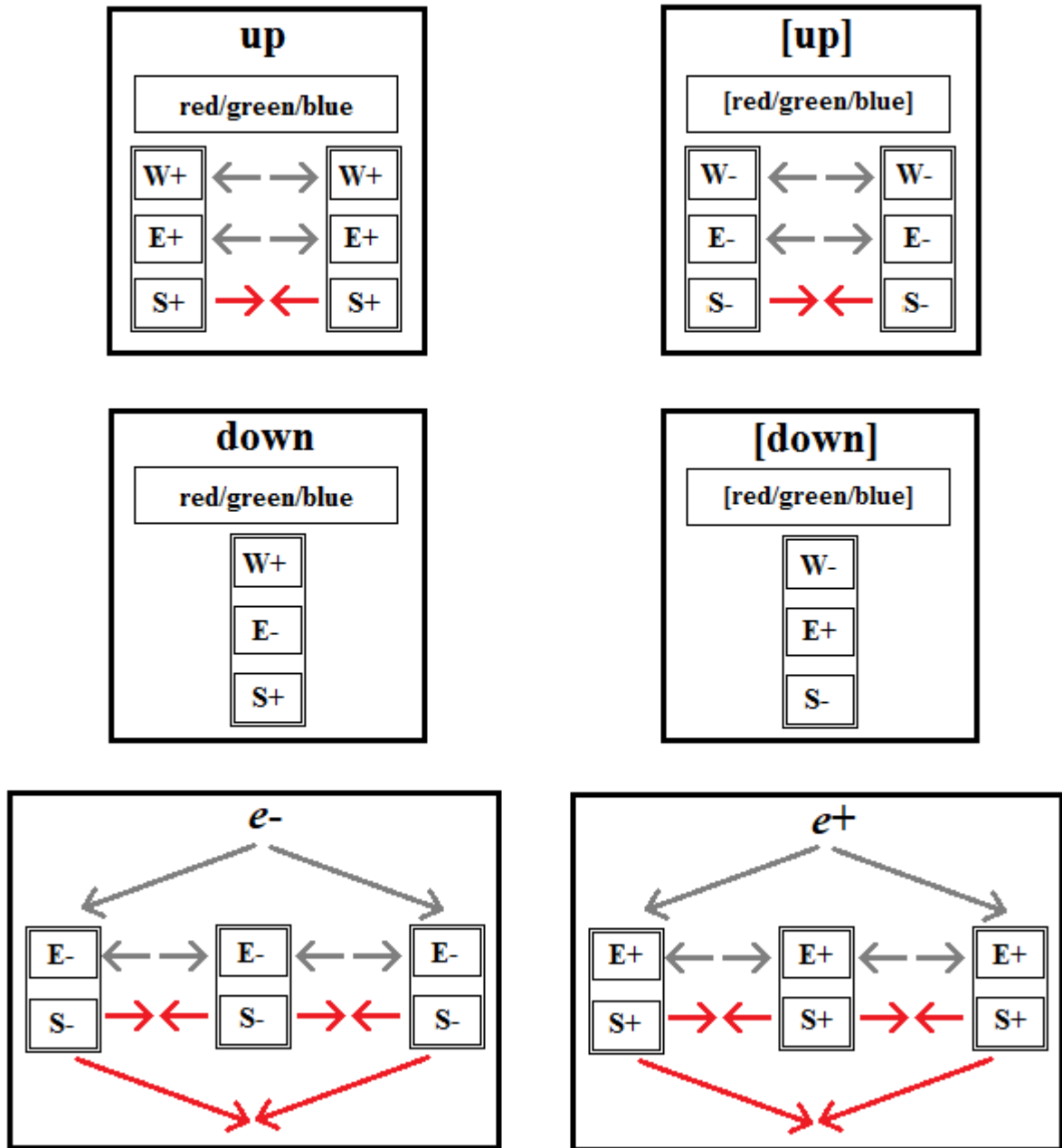

Figure 19 - Model 2, with two W+ particles in the quark up. Schemes of the quark up, [up], down, [down], of the electron (e-) and of the positron (e+).

At this point various questions arise:

- Is it possible to discriminate on a theoretical basis which of the two models is more plausible?
- By considering two types of quark (up, down) and two types of antiquark ([up], [down]), 20 different combinations with three quarks (nucleons) are possible (Table 2). In the ordinary matter, there are the combinations defined as proton and neutron, while in the antimatter there are the combinations defined as antiproton ([proton]) and antineutron ([neutron]). The other nucleons are not found in natural conditions and are unstable. Is it possible to explain why the first four combinations are stable compared to the other 16?

List of possible nucleons (in order of electric charge; duplicates eliminated)						
Quark 1	Quark 2	Quark 3	Charge	Abbrev.	Name	Abbrev.
up (+2/3)	up (+2/3)	up (+2/3)	2	uuu		
up (+2/3)	up (+2/3)	[down] (+1/3)	1 2/3	uu[d]		
up (+2/3)	[down] (+1/3)	[down] (+1/3)	1 1/3	u[d][d]		
up (+2/3)	up (+2/3)	down (-1/3)	1	uud	proton	<i>p</i>
[down] (+1/3)	[down] (+1/3)	[down] (+1/3)	1	[d][d][d]		
up (+2/3)	up (+2/3)	[up] (-2/3)	2/3	uu[u]		
up (+2/3)	down (-1/3)	[down] (+1/3)	2/3	ud[d]		
up (+2/3)	[up] (-2/3)	[down] (+1/3)	1/3	u[u][d]		
down (-1/3)	[down] (+1/3)	[down] (+1/3)	1/3	d[d][d]		
up (+2/3)	down (-1/3)	down (-1/3)	0	udd	neutron	<i>n</i>
[up] (-2/3)	[down] (+1/3)	[down] (+1/3)	0	[u][d][d]	[neutron]	[ <i>n</i> ]
up (+2/3)	down (-1/3)	[up] (-2/3)	- 1/3	ud[u]		
down (-1/3)	down (-1/3)	[down] (+1/3)	- 1/3	dd[d]		
up (+2/3)	[up] (-2/3)	[up] (-2/3)	- 2/3	u[u][u]		
down (-1/3)	[up] (-2/3)	[down] (+1/3)	- 2/3	d[u][d]		
down (-1/3)	down (-1/3)	down (-1/3)	-1	ddd		
[up] (-2/3)	[up] (-2/3)	[down] (+1/3)	-1	[u][u][d]	[proton]	[ <i>p</i> ]
down (-1/3)	down (-1/3)	[up] (-2/3)	-1 1/3	dd[u]		
down (-1/3)	[up] (-2/3)	[up] (-2/3)	-1 2/3	d[u][u]		
[up] (-2/3)	[up] (-2/3)	[up] (-2/3)	-2	[u][u][u]		
Charge >1 or <-1:						

Table 2 - All possible nucleons with 3 quarks or antiquarks. For each nucleon, the table reports the quarks that compose it, the electric charge of each quark (in fractions of that of an electron), the electric charge of the nucleon (i.e., the sum of the charges of the quarks that compose it).

Now, let us consider Table 3 and Table 4, which concern the hypotheses of one or two W<sup>+</sup> particles in each quark up (model 1 and model 2, respectively).

It is necessary to briefly discuss the concept of stability (parameter V, “relative stability Value”, proposed in the tables). Stability is not to be understood as equality between the attractive and repulsive “forces”, but as a great prevalence of the attractive “forces” over the repulsive ones. In fact, since each component is only a wave, considering the continuous oscillations of the waves, if, for example, every *m* unit of time *t* the two groups of forces are in a phase that causes disintegration, in a period *m·t* there will be a moment *t* in which the system breaks up. Consequently, *m* must be large for the system to be stable enough. The parameter V is only an arbitrary indicator of this stability and does not mean that the attractive “forces” are equal or equivalent to the antagonistic repulsive “forces”. For the system to be stable, the attractive “forces” must be several orders of magnitude greater than the repulsive “forces”.

The left side of the tables show the nucleons as listed in Table 2. The columns of the central part report the attractive or repulsive forces in arbitrary units, calculated by two elementary rules:

- 1) For each type of particle, it is considered whether the force is attractive or repulsive. For example (see line 1 of Table 3), for W<sup>+</sup> particles of the same sign, the force is repulsive because the W dimension has been hypothesized with negative curvature. As another example (see line 1 of Table 3), for S<sup>+</sup> particles of the same sign, the force is attractive because the S dimension has been hypothesized with positive curvature.



- 2) The action of each pair of particles or groups of particles is considered distinctly, attributing to the action of each pair a positive or negative value in arbitrary units according to whether the action is attractive or repulsive. For example (see line 1 of Table 3), three  $W^+$  particles form three possible pairs and then the repulsive action will be  $-1 \cdot 3 = -3$ . As another example (see line 1 of Table 3), three pairs of particles each with two  $S^+$  make an attractive value of 4 for each pair and so the total attraction will be  $3 \cdot 4 = 12$ .
- 3) For the calculation of the electric charges, the tertiary charges are considered. Therefore, the charge of an up quark =  $2 E^+$  and that of a down quark =  $1 E^-$ .

CASE 1 W+													wk	sk	ek	
List of possible nucleons (in order of electric charge; duplicates eliminated)													= 1	= 1	= 1	V
Quark 1	Quark 2	Quark 3	Charge	W<>	W><	T(W)	S><	S<>	T(S)	E<>	E><	T(E)	T(W)	T(S)	T(E)	Tot.
up	up	up	2	-3	0	-3	12	0	12	-12	0	-12	-3,0	12,0	-12,0	-3,0
2/3	2/3	2/3														
up	up	[down]	1 2/3	-1	2	1	4	-4	0	-8	0	-8	1,0	0,0	-8,0	-7,0
2/3	2/3	1/3														
up	[down]	[down]	1 1/3	-1	2	1	1	-4	-3	-5	0	-5	1,0	-3,0	-5,0	-7,0
2/3	1/3	1/3														
<b>p</b>	up	up	down	1	-3	0	-3	8	0	8	-4	4	0	8,0	0,0	5,0
2/3	2/3	-1/3														
[down]	[down]	[down]	1	-3	0	-3	3	0	3	-3	0	-3	-3,0	3,0	-3,0	-3,0
1/3	1/3	1/3														
up	up	[up]	2/3	-1	2	1	4	-8	-4	-4	8	4	1,0	-4,0	4,0	1,0
2/3	2/3	-2/3														
up	down	[down]	2/3	-1	2	1	2	-3	-1	-2	3	1	1,0	-1,0	1,0	1,0
2/3	-1/3	1/3														
up	[up]	[down]	1/3	-1	2	1	2	-6	-4	-2	6	4	1,0	-4,0	4,0	1,0
2/3	-2/3	1/3														
down	[down]	[down]	1/3	-1	2	1	1	-2	-1	-1	2	1	1,0	-1,0	1,0	1,0
-1/3	1/3	1/3														
<b>n</b>	up	down	down	0	-3	0	-3	5	0	5	-1	4	3	5,0	3,0	5,0
2/3	-1/3	-1/3														
[n]	[up]	[down]	[down]	0	-3	0	-3	5	0	5	-1	4	3	5,0	3,0	5,0
-2/3	1/3	1/3														
up	down	[up]	-1/3	-1	2	1	2	-6	-4	-2	6	4	1,0	-4,0	4,0	1,0
2/3	-1/3	-2/3														
down	down	[down]	-1/3	-1	2	1	1	-2	-1	-1	2	1	1,0	-1,0	1,0	1,0
-1/3	-1/3	1/3														
up	[up]	[up]	-2/3	-1	2	1	4	-8	-4	-4	8	4	1,0	-4,0	4,0	1,0
2/3	-2/3	-2/3														
down	[up]	[down]	-2/3	-1	2	1	2	-3	-1	-2	3	1	1,0	-1,0	1,0	1,0
-1/3	-2/3	1/3														
down	down	down	-1	-3	0	-3	3	0	3	-3	0	-3	-3,0	3,0	-3,0	-3,0
-1/3	-1/3	-1/3														
<b>[p]</b>	[up]	[up]	[down]	-1	-3	0	-3	8	0	8	-4	4	0	8,0	0,0	5,0
-2/3	-2/3	1/3														
down	down	[up]	-1 1/3	-1	2	1	1	-4	-3	-5	0	-5	1,0	-3,0	-5,0	-7,0
-1/3	-1/3	-2/3														
down	[up]	[up]	-1 2/3	-1	2	1	4	-4	0	-8	0	-8	1,0	0,0	-8,0	-7,0
-1/3	-2/3	-2/3														
[up]	[up]	[up]	-2	-3	0	-3	12	0	12	-12	0	-12	-3,0	12,0	-12,0	-3,0
-2/3	-2/3	-2/3														

Table 3 - Model 1, evaluation of the relative stability value (see text).

After calculating the attractive or repulsive forces for the particles W, S and E, the sums are reported in the columns T(W), T(S) and T(E), respectively.

In the right part of each table, these values are multiplied by fixed parameters (indicated in the upper part of each table and defined as wk, sk, ek for the first table, and wk\_2, sk\_2 and ek\_2 for the second table) in order to vary the relative weight of each force. In the first table, these parameters are always

set equal to the unit ( $w_k = s_k = e_k = 1$ ) and therefore no modification is made. In the second table, the values are:  $w_{k\_2} = 0.5$ ,  $s_{k\_2} = 1.5$ ,  $e_{k\_2} = 1$ .

Finally, in the rightmost column (Tot.), for each row, it is shown the sum of the three values that is defined as “relative stability Value” or briefly V.

The result is interesting.

In model 1, with the values assigned to the fixed parameters, for proton, neutron, [proton] and [neutron] V is equal to 5. All the other 16 nucleons have a lower V value ranging from -7 to 1.

In model 2, with the aforesaid values assigned to the fixed parameters, proton, neutron, [proton] and [neutron] have  $V = 8$ , all the other 16 nucleons have  $V=0$  or  $V=-8$ , i.e., in any case  $<8$ .

Therefore, the two tables show us that, with the values assigned to the fixed parameters, in both models, proton, neutron, [proton] and [neutron] are the most stable nucleons, while the other nucleons are unstable relative to them. However, the two tables do not allow us to discriminate which of the two models is the most likely.

CASE 2 W+													wk_2	sk_2	ek_2		
List of possible nucleons (in order of electric charge; duplicates eliminated)													= 0.5	= 1.5	= 1	V	
Quark 1	Quark 2	Quark 3	Charge	W<>	W><	T(W)	S><	S<>	T(S)	E <>	E><	T(E)	T(W)	T(S)	T(E)	Tot.	
up	up	up	2	-12	0	-12	12	0	12	-12	0	-12	-6,0	18,0	-12,0	0,0	
up	up	[down]	1 2/3	-4	4	0	4	-4	0	-8	0	-8	0,0	0,0	-8,0	-8,0	
up	[down]	[down]	1 1/3	-1	4	3	1	-4	-3	-5	0	-5	1,5	-4,5	-5,0	-8,0	
<b>p</b>	up	up	down	1	-8	0	-8	8	0	8	-4	4	0	-4,0	12,0	0,0	8,0
	[down]	[down]	[down]	1	-3	0	-3	3	0	3	-3	0	-3	-1,5	4,5	-3,0	0,0
	up	up	[up]	2/3	-4	8	4	4	-8	-4	8	4	2,0	-6,0	4,0	0,0	
	up	down	[down]	2/3	-2	3	1	2	-3	-1	-2	3	0,5	-1,5	1,0	0,0	
	up	[up]	[down]	2/3	-2	6	4	2	-6	-4	-2	6	2,0	-6,0	4,0	0,0	
	down	[down]	[down]	-1/3	1	2	1	1	-2	-1	2	1	0,5	-1,5	1,0	0,0	
<b>n</b>	up	down	down	0	-5	0	-5	5	0	5	-1	4	3	-2,5	7,5	3,0	8,0
<b>[n]</b>	[up]	[down]	[down]	0	-5	0	-5	5	0	5	-1	4	3	-2,5	7,5	3,0	8,0
	up	down	[up]	-1/3	-2	6	4	2	-6	-4	-2	6	2,0	-6,0	4,0	0,0	
	down	down	[down]	-1/3	-1	2	1	1	-2	-1	2	1	0,5	-1,5	1,0	0,0	
	up	[up]	[up]	-2/3	-4	8	4	4	-8	-4	8	4	2,0	-6,0	4,0	0,0	
	down	[up]	[down]	-1/3	-2	3	1	2	-3	-1	-2	3	0,5	-1,5	1,0	0,0	
	down	down	down	-1/3	-3	0	-3	3	0	3	-3	0	-3	-1,5	4,5	-3,0	0,0
<b>[p]</b>	[up]	[up]	[down]	-1	-8	0	-8	8	0	8	-4	4	0	-4,0	12,0	0,0	8,0
	down	down	[up]	-1 1/3	-1	4	3	1	-4	-3	-5	0	-5	1,5	-4,5	-5,0	-8,0
	down	[up]	[up]	-1 2/3	-4	4	0	4	-4	0	-8	0	-8	0,0	0,0	-8,0	-8,0
	[up]	[up]	[up]	-2	-12	0	-12	12	0	12	-12	0	-12	-6,0	18,0	-12,0	0,0

Table 4 - Model 2, evaluation of the relative stability value (see text).

This means that the knowledge of some other fact is necessary.

The interpretation of the beta- decay (neutron  $\rightarrow$  proton + electron + antineutrino [Veltman 2003, p. 200; Teramoto 2015, p. 97] according to the model 1 (which hypothesizes a single  $W^+$  particle in the quark up) is shown in Fig. 20. In this decay, a neutron becomes a proton by emitting an electron and an antineutrino:  $n \rightarrow p + e^- + [\nu]$ . In practice, as in the transformation of a neutron into a proton a quark down is transformed into a quark up, we have: down  $\rightarrow$  up +  $e^- + [\nu]$  (upper part of the figure) or  $\nu +$  down  $\rightarrow$  up +  $e^-$  (central part of the figure). The inverse of beta- decay (beta+ decay [Teramoto 2015, p. 98]) is shown in the lower part of the figure: up  $\rightarrow$  down +  $e^+ + \nu$ .

According to this interpretation, in the beta- decay two  $S^+$  particles are emitted which would constitute an antineutrino, and in the beta+ decay a neutrino, consisting of two particles  $S^-$ , would be needed.

However, it is known that “Neutrinos are exclusively sensitive to the weak force ... They only interact with other particles via the weak force ...” [Hooft 1997, p. 29-30], and therefore it is not admissible that neutrinos and antineutrinos do not contain  $W^+$  or  $W^-$  particles.

**beta- decay**

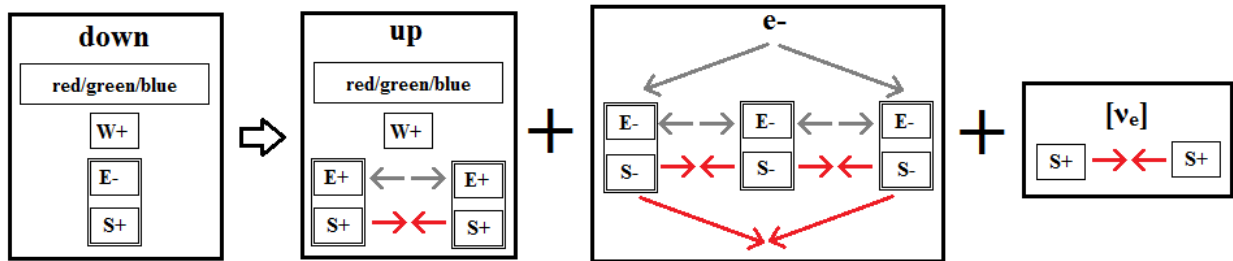

or

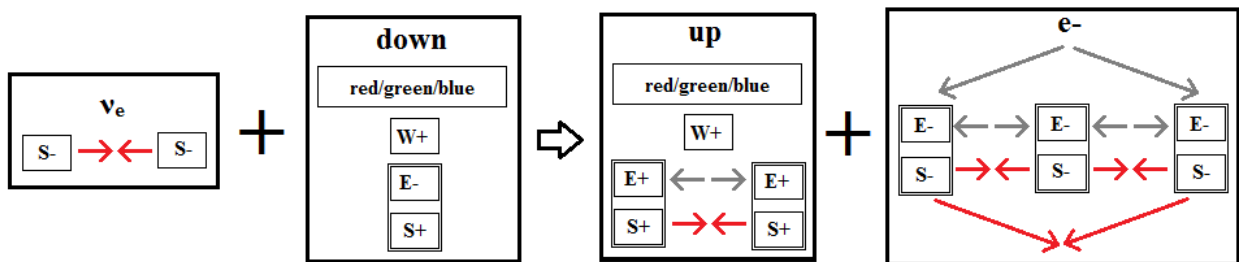

**beta+ decay**

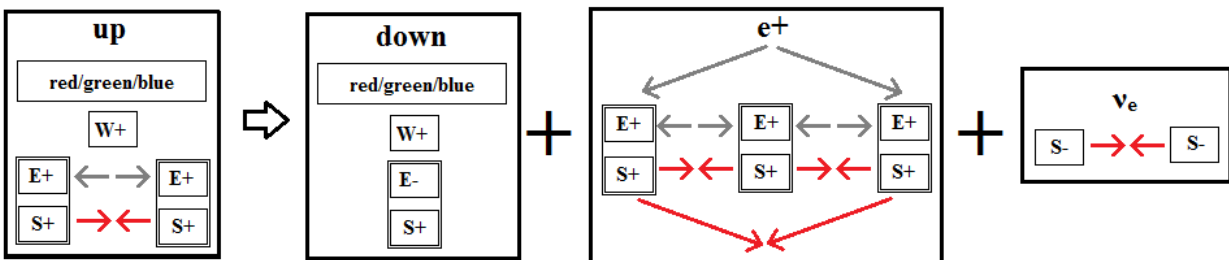
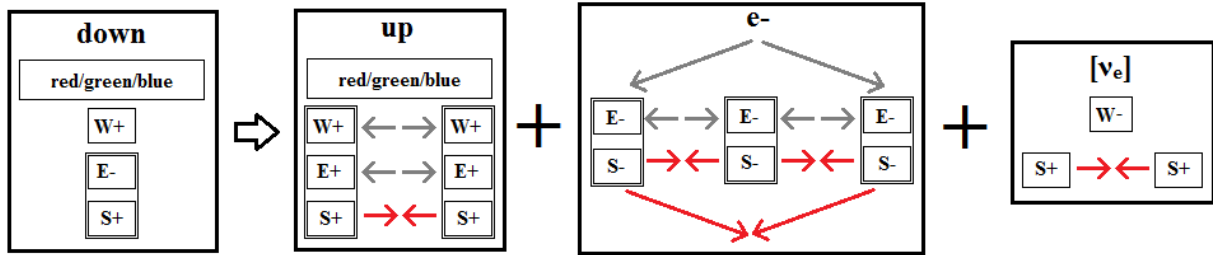

Figure 20 - Interpretation of beta- decay and beta+ decay according to model 1.

The interpretation of the model 2 is presented in Fig. 21. Here, in the beta- decay it is assumed that we obtain two  $S^+$  particles plus a  $W^-$  particle, a complex that could well be an antineutrino because it can be influenced by the weak force. In beta+ decay it is assumed that we obtain two  $S^-$  particles and a  $W^+$  particle, a complex that should be a neutrino.

Therefore, in comparison with model 1, model 2 appears likely because the hypothetical antineutrino and neutrino that would be present in the reported reactions contain a  $W^-$  or a  $W^+$  particle, respectively, and so would be sensitive to the weak force.

**beta- decay**



or

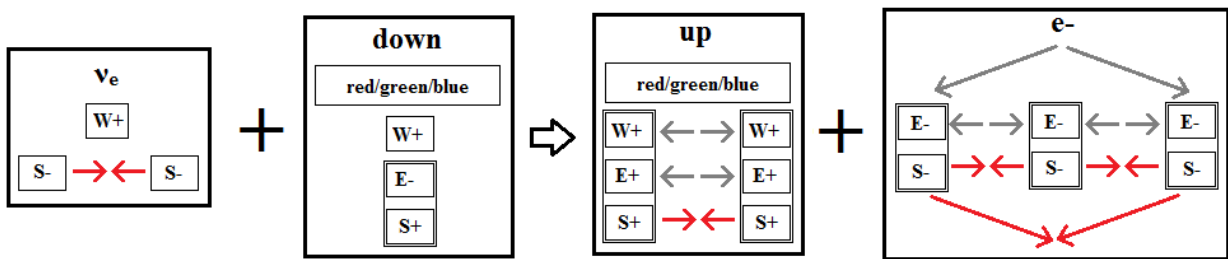

**beta+ decay**

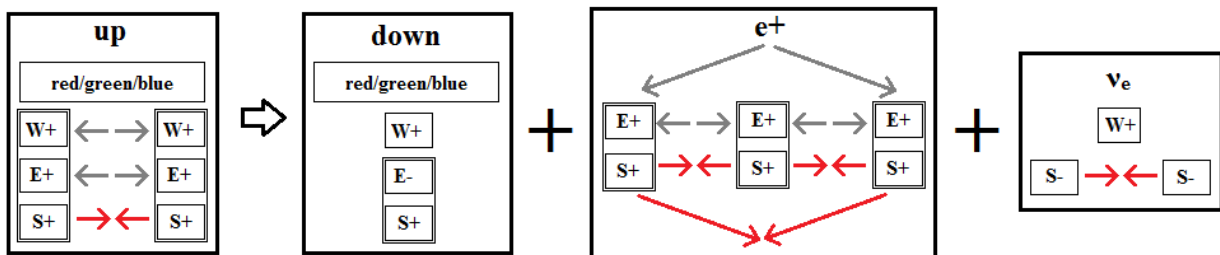

Figure 21 - Interpretation of beta- decay and beta+ decay according to model 2.

**7. About the quarks and their colors**

Now, let us discuss the colors of the quarks and some questions concerning the quarks:

--- *Questions (1) and (2) and possible answers:*

2) Why do not exist isolated quarks or aggregations of two quarks as stable entities?

- The two questions could be explained if we imagine each of the three colors as a “particle” (i.e., a flattening) of one of three distinct dimensions - “Green” (G), “Red” (R), and “Blue” (B) - with negative curvature and small  $R$  (in the range of the size of an atomic nucleus).

Two quarks with the same color cannot coexist nearby because there is repulsive force between them. This would also explain why there are no nucleons with more than three quarks.

If any G/R/B flattening is associated with a  $S^+$  flattening, nucleons with one or two quarks cannot exist in a stable way as they tend to aggregate forming groups of three quarks by action of the attractive force between  $S^+$  flattening (provided the colors are different).

This means that an isolated quark or a pair of two quarks are unstable not because they disintegrate, but as they immediately aggregate with other quarks to form a stable threesome group (i.e., a nucleon). Regarding the stability of the aggregations of two quarks or of two antiquarks (clearly of different colors), Table 5 should be seen. In this table, among 10 possible combinations, only the pairs ud and [u][d] have V=4, while the other pairs have V=0 or V=-4. Adding to these two most stable pairs, to the first u or d, and to the second [u] or [d], we obtain proton, neutron, [proton], and [neutron], respectively, which, as shown before, are the most stable groupings of 3 quarks with V=8 (while all the other groupings of 3 quarks, or nucleons, have V=0 or V=-8).

List of possible couples of quarks (in order of electric charge; duplicates eliminated)												wk_2 = 0,5	sk_2 = 1,5	ek_2 = 1	V	
Quark 1	Quark 2	Charge	W<>	W><	T(W)	S><	S<>	T(S)	E <>	E><	T(E)	T(W)	T(S)	T(E)	Tot.	
up	up	2/3	2/3	1 1/3	-4	0	-4	4	0	4	-4	-4	-2,0	6,0	-4,0	0,0
up	[down]	2/3	1/3	1	0	2	2	0	-2	-2	0	-2	1,0	-3,0	-2,0	-4,0
[down]	[down]	1/3	1/3	2/3	-1	0	-1	1	0	1	-1	-1	-0,5	1,5	-1,0	0,0
up	down	2/3	-1/3	1/3	-2	0	-2	2	0	2	2	-1,0	3,0	2,0	4,0	
up	[up]	2/3	-2/3	0	0	4	4	0	-4	-4	0	4	2,0	-6,0	4,0	0,0
down	[down]	-1/3	1/3	0	0	1	1	0	-1	-1	0	1	0,5	-1,5	1,0	0,0
[up]	[down]	-2/3	1/3	-1/3	-2	0	-2	2	0	2	2	-1,0	3,0	2,0	4,0	
down	down	-1/3	-1/3	-2/3	-1	0	-1	1	0	1	-1	-0,5	1,5	-1,0	0,0	
down	[up]	-1/3	-2/3	-1	0	2	2	0	-2	-2	0	-2	1,0	-3,0	-2,0	-4,0
[up]	[up]	-2/3	-2/3	-1 1/3	-4	0	-4	4	0	4	-4	-2,0	6,0	-4,0	0,0	

Table 5 - Evaluation of the relative stability Value (V) of the aggregations of two quarks.

--- Questions (3) and (4) and possible answers:

3) Why do the colors of the quarks appear to change?

4) Why are the three quarks of a nucleus immersed in a cloud (or glue) of gluons, which in fact constitute large part of the mass of a nucleus?

- The likely structure of a gluon is shown in Fig. 22 as formed of two W+ particles, two S+ particles and one pair of a color plus an anti-color (i.e., as a quark up without charge and with the addition of an anti-color), so that there are 9 possible combinations. Indeed, without the W+ flattening each gluon would be stably adherent to a quark, and without the S+ flattening the gluons would not be attracted by the quarks and would be expelled from the nucleus. According to this model, the gluons continuously interact with the quarks of a nucleon by exchanging the color particle and then, by another gluon, again exchanging the color particle and bringing the group of the three quarks back into the stable form in which the three colors are different. An example of such possible transformations, in two steps, is shown in Fig. 23.

This would imply that the quark trio of a nucleon is surrounded by a cloud (glue) of gluons that continually interact with each quark.

--- Questions (5) and (6) and possible answers:

5) Why do not gluons join together?

6) Why do not gluons disperse, moving away from the nucleus of the atom?

- The attractive forces between S+ flattening tend to aggregate the gluons.

- The repulsive forces between W+ flattening tend to disperse them.

The balance between such phenomena would explain (5) and (6).

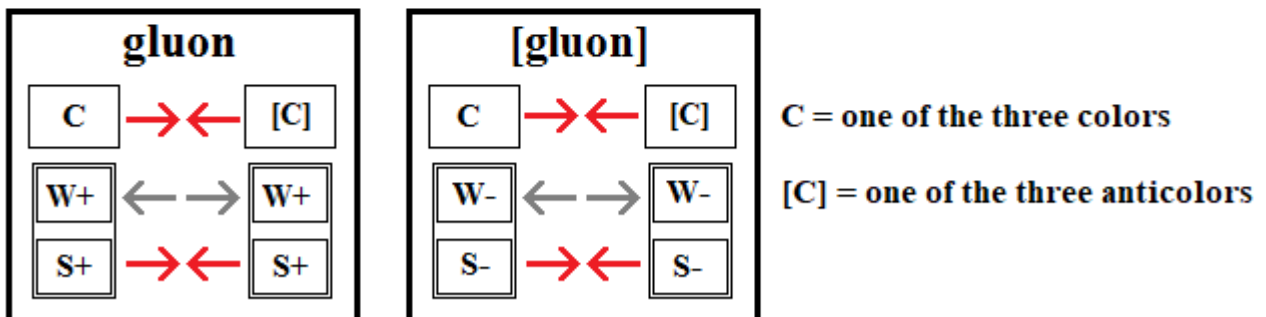
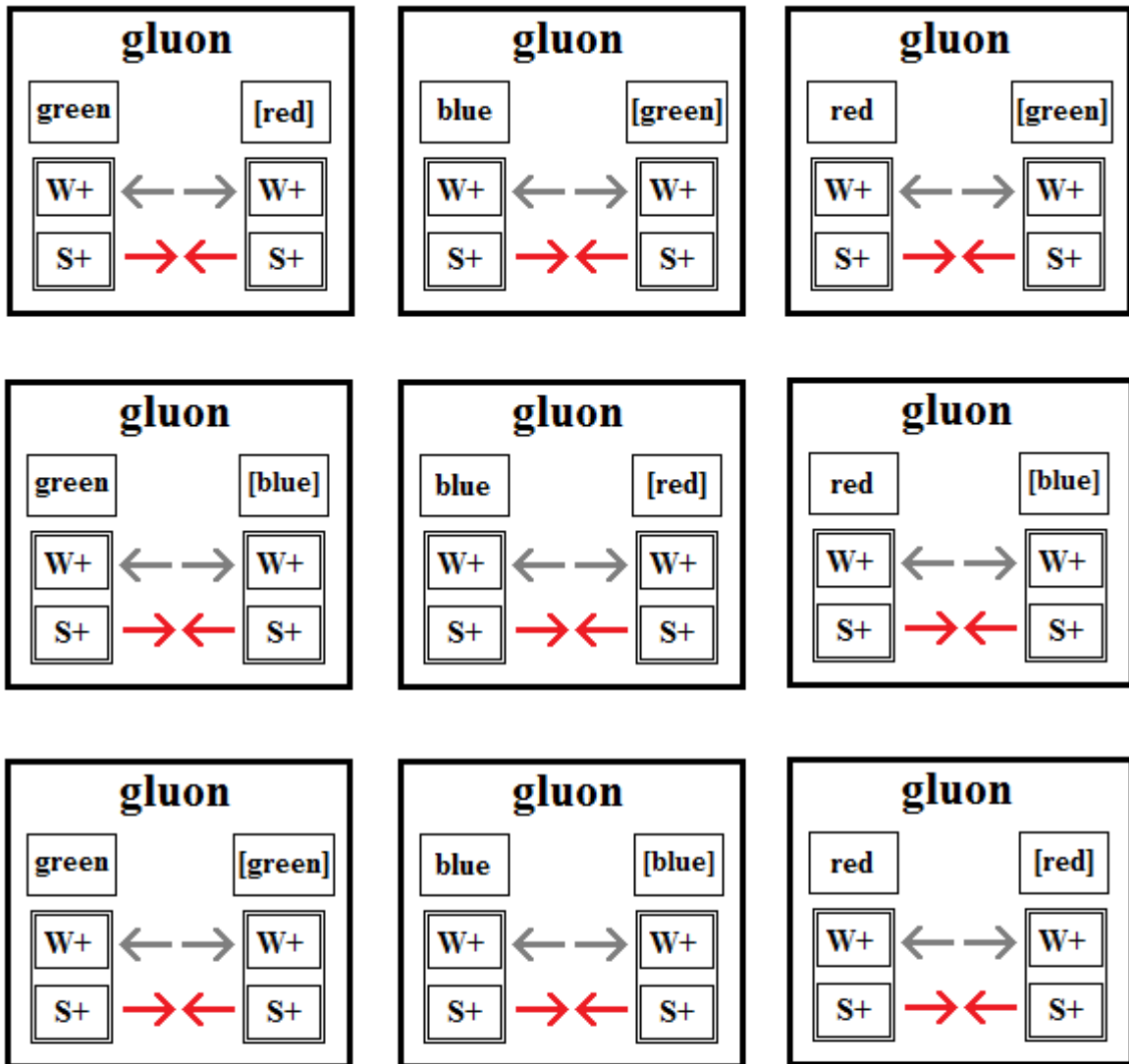

Figure 22 – Above: the nine likely types of gluons; below: scheme of the gluons and of their antigluons.

--- Questions (7) and possible answer:

7) If it is true that in a nucleon there are only three quarks with different colors because an additional quark with an already present color would be expelled (identical colors repel each other), how do we explain the presence in the nucleon of gluons in which there is always a color?

- In each gluon there is an anti-color which is attracted by the respective color. This balances the aforementioned repulsive force between identical colors and blocks the expulsion of the gluon from the nucleon.

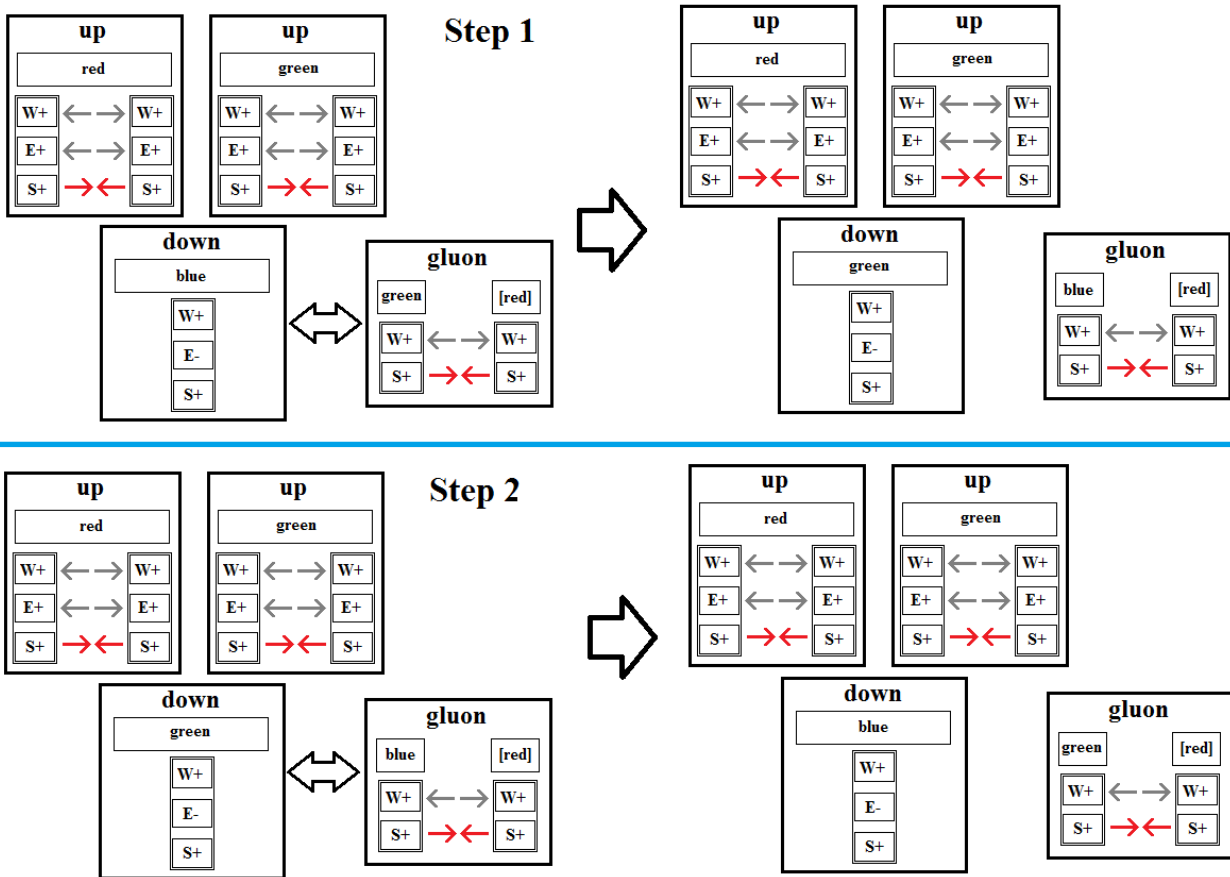

Figure 23 – An example of a cycle of interaction, in two steps, between a quark down and two gluons (in a proton). In the first step, the color of the quark down changes from blue to green by interaction with a gluon, but as two quarks have now the same color (green), the complex is unstable. In the second step, the quark down returns to the color blue and the triplet of quarks is again stable.

### 8. The mesons

The mesons are unstable aggregates of a quark and an antiquark, with the characteristic that the colors of the two quarks are different (e.g., if a quark is green the antiquark must be [red] or [blue]). Considering only the cases with the quarks u and d, and the antiquarks [u] and [d], there are four possible combinations (s. Table 6 and Fig. 24).

List of possible mesons (a quark and an antiquark) considering only u, d, [u] and [d] (in decreasing order of the value of the electric charge; duplicates eliminated)														wk_2 =	sk_2 =	ek_2 =		
														0,5	1,5	1	V	
Symbol	Quark 1	Quark 2	Charge	W<>	W><	T(W)	S><	S<>	T(S)	E<>	E><	T(E)	W	S	E	Tot.	Lifetime	
$\eta$	up	[down]																
	2/3	1/3	1	0	2	2	0	-2	-2	-2	0	-2	1,0	-3,0	-2,0	-4,0	2,60E-08	
$\pi^0$	up	[up]																
	2/3	-2/3	0	0	4	4	0	-4	-4	0	4	4	2,0	-6,0	4,0	0,0	5,60E-19	
$\pi^+$	down	[down]																
	-1/3	1/3	0	0	1	1	0	-1	-1	0	1	1	0,5	-1,5	1,0	0,0	8,40E-17	
$\pi^-$	down	[up]																
	-1/3	-2/3	-1	0	2	2	0	-2	-2	-2	0	-2	1,0	-3,0	-2,0	-4,0	2,60E-08	

Table 6 - Some mesons with the indication of the lifetime in seconds [Veltmann 2003, pp. 230-231] and the evaluation of the relative stability Value (V).

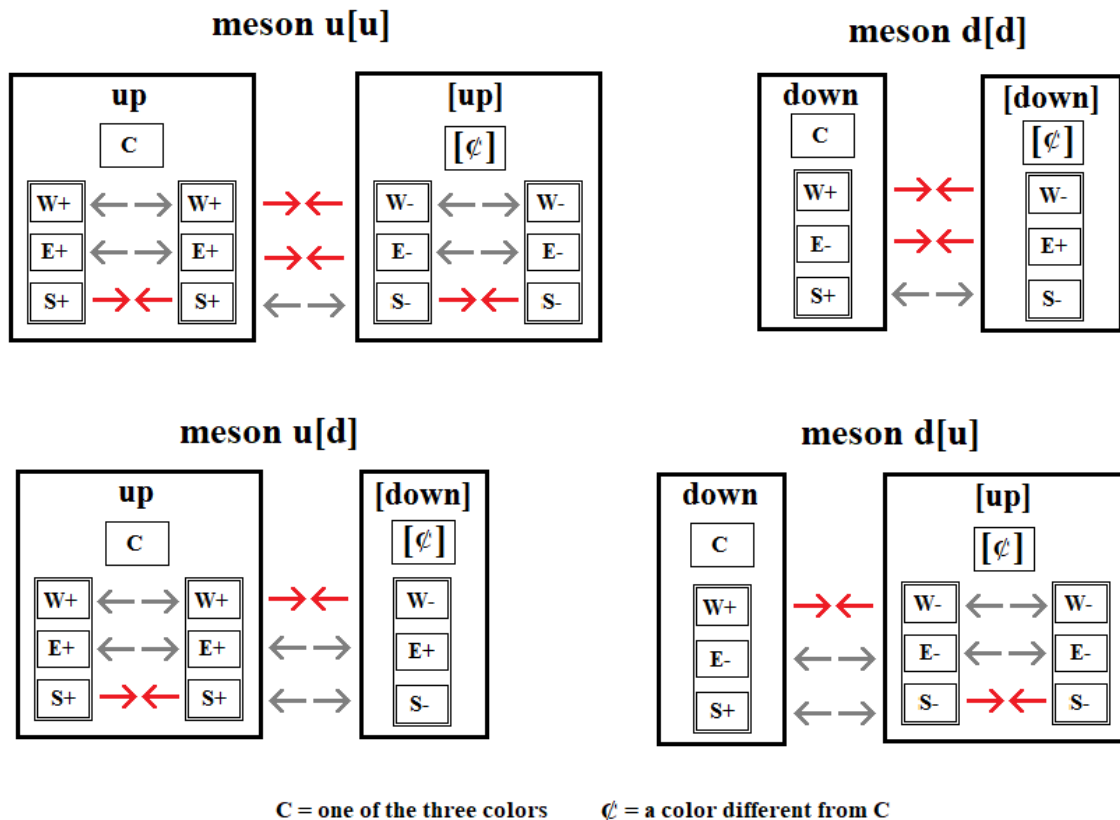

Figure 24 – Scheme of the four possible mesons considering only the quarks u, d, and the relative antiquarks.

The relative stability Values (V), reported in the column “V” of Table 6, indicate that the mesons are unstable. However, the index does not allow a faithful assessment of the degree of instability. In fact, the two combinations with V=0 have a lifetime of about 10 orders of magnitude lower than the other two combinations with V=-4.



### 9. Interpretation of some reactions with the vector bosons $W^+$ and $W^-$ and of some other reactions

Below are various reactions in which boson vectors  $W^+$  and  $W^-$  are present, and some other reactions.

The symbols used are:

$N$  = neutron;  $[N]$  = antineutron;

$P$  = proton;  $[P]$  = antiproton;

$e^-$  = electron;  $e^+$  = positron;

$\nu_e$  = electronic neutrino;  $[\nu_e]$  = electronic antineutrino;

$R/B/G$  = one of the three colors;  $[R/B/G]$  = one of the three anti-colors;

$W^+$  = weak particle;  $W^-$  = weak antiparticle;

$E^+$  = electric particle;  $E^-$  = electrical antiparticle;

$S^+$  = strong particle;  $S^-$  = strong antiparticle;

$u$  = quark up;  $[u]$  antiquark up;  $d$  = quark down;  $[d]$  = antiquark down;

$c$  = quark charm;  $s$  = quark strange;

$b$  = quark bottom;  $t$  = quark top;

$W^+$  = positive vector boson (not the weak particle,  $W^+$ );

$W^-$  = negative vector boson (not the weak antiparticle,  $W^-$ );

and, for each reaction, a possible interpretation is proposed in the following Table 7.

Table 7 – Interpretations of some reactions

Reaction 1 [Veltman 2003, p. 100]						
Particles	$u$	->	$d$	+	$W^+$	
Interpretation						Totals
W dim.	2 $W^+$	->	$W^+$	+	$W^+$	2 $W^+$ = 2 $W^+$
S dim.	2 $S^+$	->	$S^+$	+	$S^+$	2 $S^+$ = 2 $S^+$
E dim.	2 $E^+$	->	$E^-$	+	3 $E^+$	2 $E^+$ = 2 $E^+$
Charge	+2/3	->	-1/3	+	+3/3	+2/3 = +2/3
Colors	R/B/G	->	R/B/G	+	-	R/B/G = R/B/G

Reaction 2 [Veltman 2003, p. 100]						
Particles	$\nu_e$	->	$e^-$	+	$W^+$	
Interpretation						Totals
W dim.	$W^+$	->	-	+	$W^+$	1 $W^+$ = 1 $W^+$
S dim.	2 $S^-$	->	3 $S^-$	+	$S^+$	2 $S^-$ = 2 $S^-$
E dim.	-	->	3 $E^-$	+	3 $E^+$	- = -
Charge	-	->	-3/3	+	+3/3	- = -
Colors	-	->	-	+	-	- = -

Reaction 3 [Veltman 2003, p. 101]						
Particles	$W^-$	->	$[u]$	+	$d$	
Interpretation						Totals
W dim.	$W^-$	->	2 $W^-$	+	$W^+$	1 $W^-$ = 1 $W^-$
S dim.	$S^-$	->	2 $S^-$	+	$S^+$	1 $S^-$ = 1 $S^-$
E dim.	3 $E^-$	->	2 $E^-$	+	$E^-$	3 $E^-$ = 3 $E^-$
Charge	-3/3	->	-2/3	+	-1/3	-3/3 = -3/3
Colors	-	->	$[R/B/G]$	+	R/B/G	- = -

Reaction 4 [Veltman 2003, p. 101]

Particles	<b>W<sup>-</sup></b>	->	[ <b>v<sub>e</sub></b> ]	+	<b>e<sup>-</sup></b>	
Interpretation						Totals
W dim.	W-	->	W-	+	-	1 W- = 1 W-
S dim.	S-	->	2 S+	+	3 S-	1 S- = 1 S-
E dim.	3 E-	->	-	+	3 E-	3 E- = 3 E-
Charge	-3/3	->	-	+	-3/3	-3/3 = -3/3
Colors	-	->	-	+	-	- = -

Reaction 5 [Rohlf 1994]

Particles	<b>W<sup>+</sup></b>	->	<b>v<sub>e</sub></b>	+	<b>e<sup>+</sup></b>	
Interpretation						Totals
W dim.	W+	->	W+	+	-	1 W+ = 1 W+
S dim.	S+	->	2 S-	+	3 S+	1 S+ = 1 S+
E dim.	3 E+	->	-	+	3 E+	3 E+ = 3 E+
Charge	+3/3	->	-	+	+3/3	+3/3 = +3/3
Colors	-	->	-	+	-	- = -

Reaction 6 [Veltman 2003, p. 101]

Particles	<b>u</b>	->	<b>s</b>	+	<b>W<sup>+</sup></b>	
Interpretation						Totals
W dim.	2 W+	->	W+	+	W+	2 W+ = 2 W+
S dim.	2 S+	->	S+	+	S+	2 S+ = 2 S+
E dim.	2 E+	->	E-	+	3 E+	2 E+ = 2 E+
Charge	+2/3	->	-1/3	+	+3/3	+2/3 = +2/3
Colors	R/B/G	->	R/B/G	+	-	R/B/G = R/B/G

Reaction 7 [Veltman 2003, p. 101]

Particles	<b>W<sup>-</sup></b>	->	[ <b>u</b> ]	+	<b>s</b>	
Interpretation						Totals
W dim.	W-	->	2 W-	+	W+	1 W- = 1 W-
S dim.	S-	->	2 S-	+	S+	1 S- = 1 S-
E dim.	3 E-	->	2 E-	+	E-	3 E- = 3 E-
Charge	-3/3	->	-2/3	+	-1/3	-3/3 = -3/3
Colors	-	->	[R/B/G]	+	R/B/G	- = -

Reaction 8 [Rohlf 1994]

Particles	<b>s</b>	->	<b>u</b>	+	<b>W<sup>-</sup></b>	
Interpretation						Totals
W dim.	W+	->	2 W+	+	W-	W+ = W+
S dim.	S+	->	2 S+	+	S-	S+ = S+
E dim.	E-	->	2 E+	+	3 E-	E- = E-
Charge	-1/3	->	+2/3	+	-3/3	-1/3 = -1/3
Colors	R/B/G	->	R/B/G	+	-	R/B/G = R/B/G

Reaction 9 [Veltman 2003, p. 101]

Particles	<b>c</b>	->	<b>s</b>	+	<b>W<sup>+</sup></b>	
Interpretation						Totals
W dim.	2 W+	->	W+	+	W+	2 W+ = 2 W+

S dim.	2 S+	->	S+	+	S+	2 S+ = 2 S+
E dim.	2 E+	->	E-	+	3 E+	2 E+ = 2 E+
Charge	+2/3	->	-1/3	+	+3/3	+2/3 = +2/3
Colors	R/B/G	->	R/B/G	+	-	R/B/G = R/B/G

Reaction 10 [Rohlf 1994]

Particles	$b$	->	$c$	+	$W^-$	
Interpretation						Totals
W dim.	W+	->	2 W+	+	W-	W+ = W+
S dim.	S+	->	2 S+	+	S-	S+ = S+
E dim.	E-	->	2 E+	+	3 E-	E- = E-
Charge	-1/3	->	+2/3	+	-3/3	-1/3 = -1/3
Colors	R/B/G	->	R/B/G	+	-	R/B/G = R/B/G

Reaction 11 [Rohlf 1994]

Particles	$t$	->	$b$	+	$W^+$	
Interpretation						Totals
W dim.	2 W+	->	W+	+	W+	2 W+ = 2 W+
S dim.	2 S+	->	S+	+	S+	2 S+ = 2 S+
E dim.	2 E+	->	E-	+	3 E+	2 E+ = 2 E+
Charge	+2/3	->	-1/3	+	+3/3	+2/3 = +2/3
Colors	R/B/G	->	R/B/G	+	-	R/B/G = R/B/G

Reaction 12 [Veltman 2003, p. 101]

Particles	$c$	->	$d$	+	$W^+$	
Interpretation						Totals
W dim.	2 W+	->	W+	+	W+	2 W+ = 2 W+
S dim.	2 S+	->	S+	+	S+	2 S+ = 2 S+
E dim.	2 E+	->	E-	+	3 E+	2 E+ = 2 E+
Charge	+2/3	->	-1/3	+	+3/3	+2/3 = +2/3
Colors	R/B/G	->	R/B/G	+	-	R/B/G = R/B/G

Reaction 13 [Veltman 2003, p. 79]

Particles	$e^-$	->	$\nu_e$	+	$W^-$	
Interpretation						Totals
W dim.	-	->	W+	+	W-	- = -
S dim.	3 S-	->	2 S-	+	S-	3 S- = 3 S-
E dim.	3 E-	->	-	+	3 E-	3 E- = 3 E-
Charge	-3/3	->	-	+	-3/3	-3/3 = -3/3
Colors	-	->	-	+	-	- = -

Reaction 14 [Veltman 2003, p. 79]

Particles	$\nu_e$	->	$e^-$	+	$W^+$	
Interpretation						Totals
W dim.	W+	->	-	+	W+	1 W+ = 1 W+
S dim.	2 S-	->	3 S-	+	S+	2 S- = 2 S-
E dim.	-	->	3 E-	+	3 E+	- = -
Charge	-	->	-3/3	+	+3/3	- = -
Colors	-	->	-	+	-	- = -

Reaction 15 [Veltman 2003, p. 52]

Particles	$[\nu_e]$	+	P	->	N	+	$e^+$	
Interpretation								Totals
W dim.	W-	+	5 W+	->	4 W+	+	-	4 W+ = 4 W+
S dim.	2 S+	+	5 S+	->	4 S+	+	3 S+	7 S+ = 7 S+
E dim.	-	+	4 E+, E-	->	2 E+, 2 E-	+	3 E+	3 E+ = 3 E+
Charge	-	+	+3/3	->	-	+	+3/3	+3/3 = +3/3
Colors	-	+	R+B+G	->	R+B+G	+	-	R+B+G = R+B+G

Reaction 16 [Veltman 2003, p. 26] (Beta- decay [Teramoto 2015, p. 97])

Particles	N	->	P	+	$e^-$	+	$[\nu_e]$	
Interpretation								Totals
W dim.	4 W+	->	5 W+	+	-	+	W-	4 W+ = 4 W+
S dim.	4 S+	->	5 S+	+	3 S-	+	2 S+	4 S+ = 4 S+
E dim.	2 E-, 2 E+	->	4E+, E-	+	3 E-	+	-	- = -
Charge	0	->	+3/3	+	-3/3	+	-	- = -
Colors	R+B+G	->	R+B+G	+	-	+	-	R+B+G = R+B+G

Reaction 17 (Beta+ decay [Teramoto 2015, p. 98])

Particles	P	->	N	+	$e^+$	+	$\nu_e$	
Interpretation								Totals
W dim.	5 W+	->	4 W+	+	-	+	W+	5 W+ = 5 W+
S dim.	5 S+	->	4 S+	+	3 S+	+	2 S-	5 S+ = 5 S+
E dim.	4 E+, E-	->	2 E-, 2 E+	+	3 E+	+	-	3 E+ = 3 E+
Charge	+3/3	->	0	+	+3/3	+	-	+3/3 = +3/3
Colors	R+B+G	->	R+B+G	+	-	+	-	R+B+G = R+B+G

Reaction 18 [Veltman 2003, p. 52]

Particles	[N]	->	[P]	+	$e^+$	+	$\nu_e$	
Interpretation								Totals
W dim.	4 W-	->	5 W-	+	-	+	W+	4 W- = 4 W-
S dim.	4 S-	->	5 S-	+	3 S+	+	2 S-	4 S- = 4 S-
E dim.	2 E-, 2 E+	->	4E-, E+	+	3 E+	+	-	- = -
Charge	-	->	-3/3	+	+3/3	+	-	- = -
Colors	[R+B+G]	->	[R+B+G]	+	-	+	-	[R+B+G] = [R+B+G]

If the compositions of  $\mathbf{W}^+$ ,  $\mathbf{W}^-$ ,  $c$ ,  $s$ ,  $b$ , and  $t$  are unknown, the aforementioned reactions allow us to establish them in a manner consistent with what said earlier and with the whole of the same reactions. The rightmost column allows to verify the perfect equivalence between the right and the left part of the reaction. The penultimate line represents the calculation of the electrical charges of the particles, i.e., the sum of  $E^+$  and  $E^-$  particles.

The reactions would indicate that  $\mathbf{W}^+$  is composed of  $\{1 W^+, 3 E^+, 1 S^+\}$ , and is unstable because there are three  $E^+$ . Similarly,  $\mathbf{W}^-$  is composed of  $\{1 W^-, 3 E^-, 1 S^-\}$ , i.e., its components are the antiparticles of the components of  $\mathbf{W}^+$ , and is similarly unstable. In the reactions it is essential to give

to  $e^-$  the composition  $\{3 E^-, 3 S^-\}$ . Furthermore, it is also necessary to set the neutrino equal to  $\{W^+, 2 S^-\}$  and the antineutrino equal to  $\{W^-, 2 S^+\}$ .

The reactions indicate that the quarks  $u$ ,  $c$  and  $t$  would have the same composition as elementary “particles”, in spite of huge differences in their masses ( $u = 2.2 \text{ MeV}$ ;  $c = 1.27 \text{ GeV}$ ;  $t = 173 \text{ GeV}$ ) [Patrignani et al. 2016, p. 36], which needs an explanation. Similarly, the reactions indicate that the quarks  $d$ ,  $s$  and  $b$  would have the same composition as elementary “particles”, in spite of huge differences in their masses ( $d = 4.7 \text{ MeV}$ ;  $s = 96 \text{ MeV}$ ;  $b = 4.18 \text{ GeV}$ ) [Patrignani et al. 2016, p. 36], which needs an explanation too.

Even the masses of  $W^+$  and  $W^-$  (80.38 GeV [Patrignani et al. 2016, p. 29]) are not congruent with the masses of the other particles in the reactions where they are present.

E.g., see the reactions from 1 to 5, and, in particular, the combination of the reactions 1 and 5:

Reaction 1 [Veltman 2003, p. 100] + Reaction 5 [Rohlf 1994]

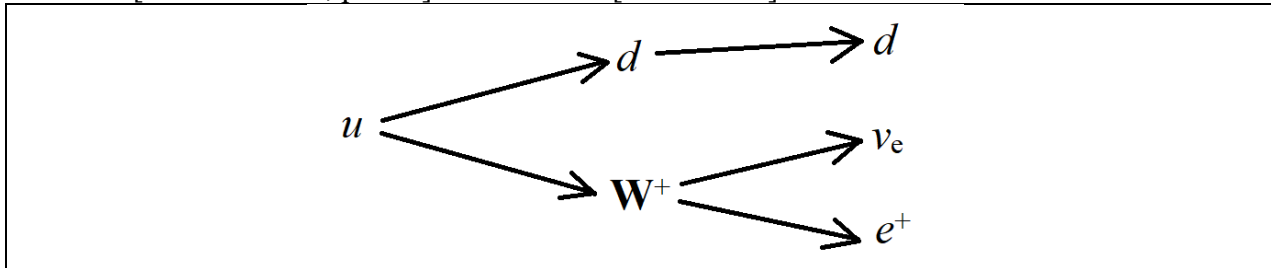

Particles	$u$	->	$d$	+	$W^+$	->	$d$	+	$\nu_e$	+	$e^+$
Interpretation											
W dim.	2 W+	->	W+	+	W+	->	W+	+	W+	+	-
S dim.	2 S+	->	S+	+	S+	->	S+	+	2 S-	+	3 S+
E dim.	2 E+	->	E-	+	3 E+	->	E-	+	-	+	3 E+
Charge	+2/3	->	-1/3	+	+3/3	->	-1/3	+	-	+	+3/3
Colors	R/B/G	->	R/B/G	+	-	->	R/B/G	+	-	+	-
Energy (GeV)	0.005		0.01		80.3		0.01		0		0.0005
	Totals		Totals				Totals				
W dim.	2 W+	=	2 W+			=	2 W+				
S dim.	2 S+	=	2 S+			=	2 S+				
E dim.	2 E+	=	2 E+			=	2 E+				
Charge	+2/3	=	+2/3			=	+2/3				
Colors	R/B/G	=	R/B/G			=	R/B/G				
Energy (GeV)	0.005	≠	80.31			≠	0.0105				

This is currently explained by saying that  $W^+$  e  $W^-$  are “virtual particles”. In fact, immediately after their “formation”, they decay into other particles.

However, it is not clear what the term “virtual particle” means and how such a particle can have a very large mass. In fact:  $u = 2.2 \text{ MeV}$ ;  $d = 4.7 \text{ MeV}$ ;  $W^+ = 80.38 \text{ GeV} = 80,380 \text{ MeV}$  [Patrignani et al. 2016, pp. 29 and 36].

## 10. The Newtonian dimensions

As at the atomic level the convergent/divergent deviations caused by the flattening in the three Newtonian or Spatial dimensions (“gravitational attractions/repulsions”) are much smaller than that caused by the “forces” defined as Weak (W), Strong (S), Electromagnetic (E), and by those caused by the colors of the quarks, so far, the flattening of the Newtonian dimensions have been neglected. Let us now try to insert these dimensions (N, N', N'') in the diagrams of the reactions of the “particles”. For simplicity the following symbols will be used:

N+ = flattening with positive rotation of N or N' or N'';

N- = flattening with negative rotation of N or N' or N''.

A complex “particle” with a N+ flattening has a mass that grows with the speed of the flattening in its Spatial dimension, as described by Einstein’s equations.

Similarly, a complex “particle” with a N- flattening has a mass that grows in relation to the speed of the flattening in its Spatial dimension.

Since the electron has a positive mass, if we assume that it includes three flattening N+ (one for each of the three dimensions N, N' and N''), in order to balance the nuclear reaction defined as beta-decay, as well as other reactions and equivalences, it appears necessary to assume that the quark u has two N- and the quark d has one N+. In fact, it is necessary to satisfy the following reactions and equivalences:

Reaction 16 [Veltman 2003, p. 26] (Beta- decay [Teramoto 2015, p. 97])

Particles	N	->	P	+	e <sup>-</sup>	+	[v <sub>e</sub> ]	Totale:
	(z N <sup>+</sup> ) n	->	N <sup>-</sup> N <sup>-</sup> N <sup>-</sup> + (z N <sup>+</sup> ) n	+	N <sup>+</sup> N <sup>+</sup> N <sup>+</sup>	+	-	(z N <sup>+</sup> ) n = (z N <sup>+</sup> ) n

Beta- decay [Veltman 2003, p. 200]

Particles	d	->	u	+	e <sup>-</sup>	+	[v <sub>e</sub> ]	Totale:
	N <sup>+</sup>	->	N <sup>-</sup> N <sup>-</sup>	+	N <sup>+</sup> N <sup>+</sup> N <sup>+</sup>	+	-	N <sup>+</sup> = N <sup>+</sup>

protone, P =	u	+	u	+	d	+	{G}	Totale:
	N <sup>-</sup> N <sup>-</sup>	+	N <sup>-</sup> N <sup>-</sup>	+	N <sup>+</sup>	+	(z N <sup>+</sup> ) n	N <sup>-</sup> N <sup>-</sup> N <sup>-</sup> + (z N <sup>+</sup> ) n

Without {G}: P = N<sup>-</sup>N<sup>-</sup>N<sup>-</sup>

neutrone, N =	u	+	d	+	d	+	{G}	Totale:
	N <sup>-</sup> N <sup>-</sup>	+	N <sup>+</sup>	+	N <sup>+</sup>		(z N <sup>+</sup> ) n	(z N <sup>+</sup> ) n

Without {G}: N = -

From this we have a series of compositions which are summarized in Tables 8 and 9, and in Figures 25, 26 and 27. Among other things, it should be noted that:

- The theoretical prediction that in the proton (but not in the neutron) there is antimatter, or rather an excess of antimatter, is confirmed in recent works (e.g., [Dove et al. 2021]).
- To justify the large difference in mass between proton (or neutron) and electron, it appears necessary to hypothesize that, in the proton and in the neutron, there is a certain number of gluons with z N+ flattening (z = 1? / 2? / 3?) and in rapid movement which increases their mass (blob of gluons, {G}). If there were no such gluons, the mass of the proton would be negative and that of the neutron would be zero. It should be noted that gluons are usually described as massless [Patrignani et al. 2016, p. 29] and that the mass of the proton or neutron would be due to the binding energy between the gluons (and between the gluons and quarks);
- The gluons must be in equal number (n) for proton and neutron.

Table 8 - Composition of various particles with regard to the dimensions N

Particles				Antiparticles				
electron, $e^- =$	$N^+N^+N^+$				positron, $e^+ =$	$N^-N^-N^-$		
quark up, $u =$	$N^-N^-$				antiquark up, $[u] =$	$N^+N^+$		
quark down, $d =$	$N^+$				antiquark down, $[d] =$	$N^-$		
quark charm, $c =$	$N^-N^-$				antiquark charm, $[c] =$	$N^+N^+$		
quark strange, $s =$	$N^+$				antiquark strange, $[s] =$	$N^-$		
quark top, $t =$	$N^-N^-$				antiquark top, $[t] =$	$N^+N^+$		
quark bottom, $b =$	$N^+$				antiquark bottom, $[b] =$	$N^-$		
gluon =	$N^+N^+$				[gluon] =	$N^-N^-$		
blob of gluons, $\{G\} =$	$(N^+N^+) n$				blob of [gluon]s, $\{[G]\} =$	$(N^-N^-) n$		
proton, $P =$	$u$	+	$u$	+	$d$	+	$\{G\}$	Total: $N^-N^-N^- + (z N^+) n$
	$N^-N^-$	+	$N^-N^-$	+	$N^+$	+	$(z N^+) n$	
neutron, $N =$	$u$	+	$d$	+	$d$	+	$\{G\}$	Total: $(z N^+) n$
	$N^-N^-$	+	$N^+$	+	$N^+$	+	$(z N^+) n$	
antiproton, $[P] =$	$[u]$	+	$[u]$	+	$[d]$	+	$\{[G]\}$	Total: $N^+N^+N^+ + (z N^-) n$
	$N^+N^+$	+	$N^+N^+$	+	$N^-$	+	$(z N^-) n$	
antineutron, $[N] =$	$[u]$	+	$[d]$	+	$[d]$	+	$\{[G]\}$	Total: $(z N^-) n$
	$N^+N^+$	+	$N^-$	+	$N^-$	+	$(z N^-) n$	

Table 9 - Interpretation of various reactions in relation to the dimensions N.

Reaction 1 [Veltman 2003, p. 100]							
Particles	$u$	->	$d$	+	$W^+$		Total: $N^-N^- = N^-N^-$
	$N^-N^-$	->	$N^+$		$N^-N^-N^-$		
Reaction 2 [Veltman 2003, p. 100]							
Particles	$\nu_e$	->	$e^-$	+	$W^+$		Total: - = -
	-	->	$N^+N^+N^+$	+	$N^-N^-N^-$		
Reaction 3 [Veltman 2003, p. 101]							
Particles	$W^-$	->	$[u]$	+	$d$		Total: $N^+N^+N^+ = N^+N^+N^+$
	$N^+N^+N^+$	->	$N^+N^+$	+	$N^+$		
Reaction 4 [Veltman 2003, p. 101]							
Particles	$W^-$	->	$[\nu_e]$	+	$e^-$		Total: $N^+N^+N^+ = N^+N^+N^+$
	$N^+N^+N^+$	->	-	+	$N^+N^+N^+$		
Reaction 5 [Rohlf 1994]							
Particles	$W^+$	->	$\nu_e$	+	$e^+$		Total: $N^-N^-N^- = N^-N^-N^-$
	$N^-N^-N^-$	->	-	+	$N^-N^-N^-$		
Reaction 6 [Veltman 2003, p. 101]							
Particles	$u$	->	$s$	+	$W^+$		Total: $N^-N^- = N^-N^-$
	$N^-N^-$	->	$N^+$	+	$N^-N^-N^-$		

Reaction 7 [Veltman 2003, p. 101]

Particles	$W^-$	->	$[u]$	+	$s$		Total:
	$N^+N^+N^+$	->	$N^+N^+$	+	$N^+$		$N^+N^+N^+ = N^+N^+N^+$

Reaction 8 [Rohlf 1994]

Particles	$s$	->	$u$	+	$W^-$		Total:
	$N^+$	->	$N^-N^-$	+	$N^+N^+N^+$		$N^+ = N^+$

Reaction 9 [Veltman 2003, p. 101]

Particles	$c$	->	$s$	+	$W^+$		Total:
	$N^-N^-$	->	$N^+$	+	$N^-N^-N^-$		$N^-N^- = N^-N^-$

Reaction 10 [Rohlf 1994]

Particles	$b$	->	$c$	+	$W^-$		Total:
	$N^+$	->	$N^-N^-$	+	$N^+N^+N^+$		$N^+ = N^+$

Reaction 11 [Rohlf 1994]

Particles	$t$	->	$b$	+	$W^+$		Total:
	$N^-N^-$	->	$N^+$	+	$N^-N^-N^-$		$N^-N^- = N^-N^-$

Reaction 12 [Veltman 2003, p. 101]

Particles	$c$	->	$d$	+	$W^+$		Total:
	$N^-N^-$	->	$N^+$	+	$N^-N^-N^-$		$N^-N^- = N^-N^-$

Reaction 13 [Veltman 2003, p. 79]

Particles	$e^-$	->	$\nu_e$	+	$W^-$		Total:
	$N^+N^+N^+$	->	-	+	$N^+N^+N^+$		$N^+N^+N^+ = N^+N^+N^+$

Reaction 14 [Veltman 2003, p. 79]

Particles	$\nu_e$	->	$e^-$	+	$W^+$		Total:
	-	->	$N^+N^+N^+$	+	$N^-N^-N^-$		- = -

Reaction 15 [Veltman 2003, p. 52]

Particles	$[\nu_e]$	+	P	->	N	+	$e^+$	Total:
	-	+	$N^-N^-N^+ + (z N^+)n$	->	$(z N^+)n$	+	$N^-N^-N^-$	$N^-N^-N^+ + (z N^+)n = N^-N^-N^+ + (z N^+)n$

Reaction 16 [Veltman 2003, p. 26] (Beta- decay [Teramoto 2015, p. 97])

Particles	N	->	P	+	$e^-$	+	$[\nu_e]$	Total:
	$(z N^+)n$	->	$N^-N^-N^+ + (z N^+)n$	+	$N^+N^+N^+$	+	-	$(z N^+)n = (z N^+)n$

Reaction 17 (Beta+ decay [Teramoto 2015, p. 98])

Particles	P	->	N	+	$e^+$	+	$\nu_e$	Total:
	$N^-N^-N^+ + (z N^+)n$	->	$(z N^+)n$	+	$N^-N^-N^-$		-	$N^-N^-N^+ + (z N^+)n = N^-N^-N^+ + (z N^+)n$



Reaction 18 [Veltman 2003, p. 52]

Particles	[N]	->	[P]	+	$e^+$	+	$\nu_e$	Total: $(z N^-) n = (z N^-) n$
	$(z N^-) n$	->	$N^+N^+N^+ + (z N^-) n$	+	$N^-N^-N^-$	+	-	

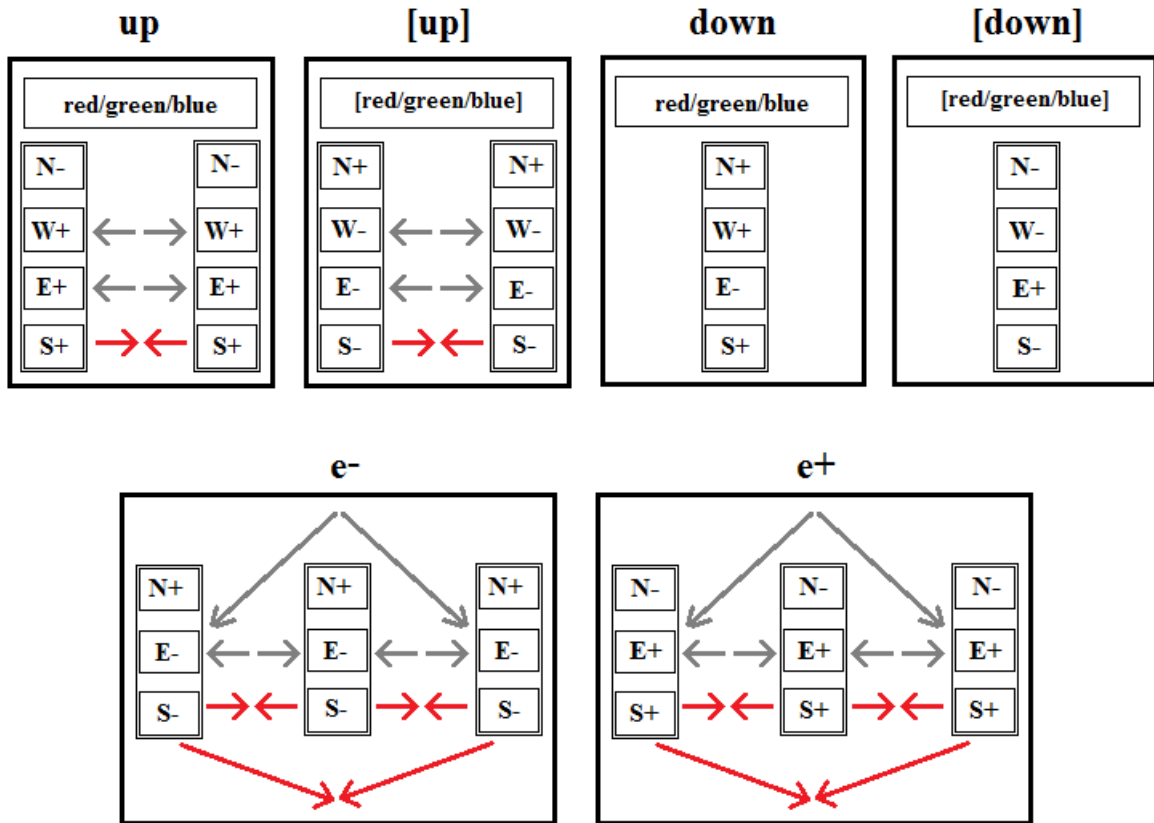

Figure 25 – Possible flattening of Newtonian (Spatial) dimensions and of other dimensions in the quarks  $u$ ,  $d$ ; the antiquarks  $[u]$ ,  $[d]$ , the electron ( $e^-$ ) and the positron ( $e^+$ ).

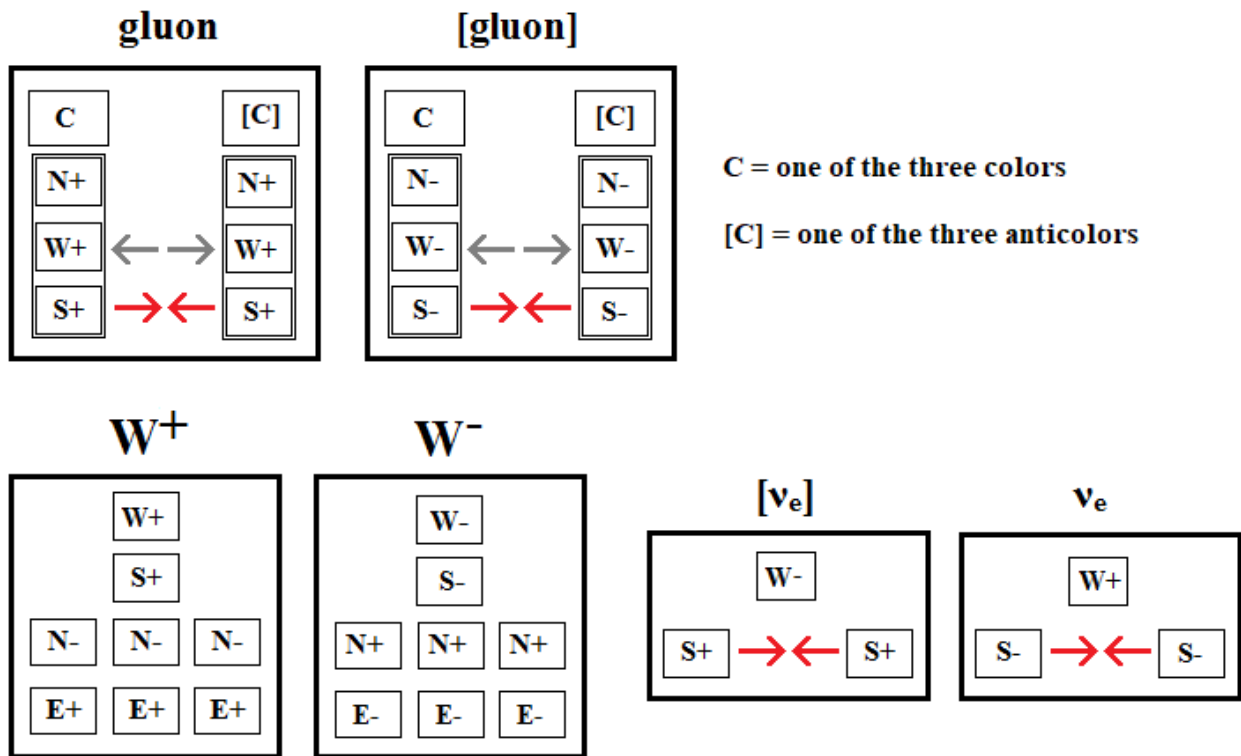

Figure 26 - Possible flattening of Newtonian (Spatial) dimensions and of other dimensions in the gluons, and in the particles  $W^+$  and  $W^-$  (not to be confused with the flattening in the Weak dimension, indicated by the symbols  $W^+$  e  $W^-$ ). Gluons are usually described as having zero mass. Electronic neutrino and antineutrino must have no flattening in Newtonian dimensions to explain their very low or null mass.

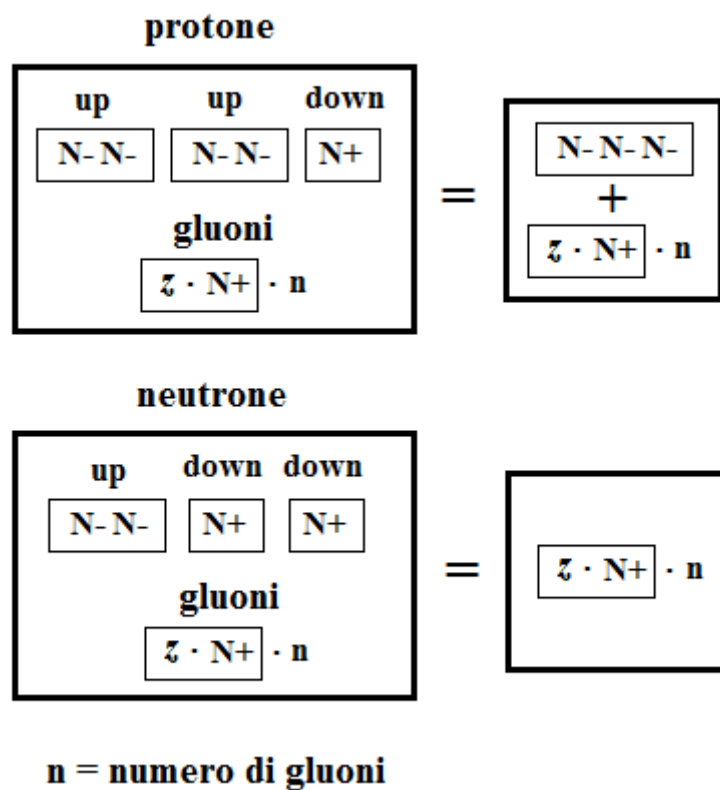

Figure 27 - Possible flattening of Newtonian (Spatial) dimensions (flattening for other dimensions not indicated) in the proton and the neutron.

## 11. Maximum speed and acceleration in a dimension

Speed is the relationship between two quantities: distance covered and time taken to cover the distance. If the time is considered as a dimension with zero (or very small) curvature, and the distance covered as a segment on the curved surface of another dimension, velocity can be represented as the relationship between the two catheti of a right triangle placed on the surface of a cylinder (Fig. 28).

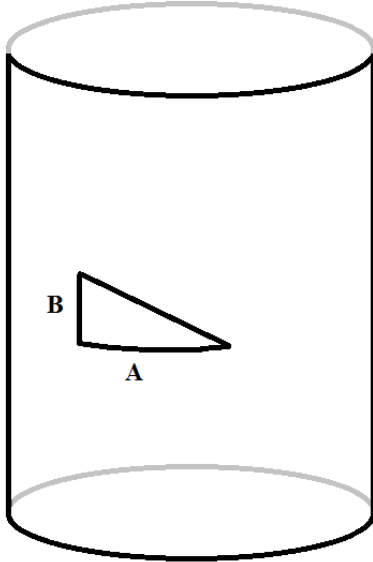

Figure 28 - Speed can be represented as the ratio between the catheti A and B on the lateral surface of a cylinder. A is a segment of a curved dimension (e.g., a Spatial dimension) and B is a segment of a flat (or almost flat) dimension (Time dimension).

Clearly, the maximum possible speed is when there is the greatest A/B ratio.

The smallest value of B cannot be less than the Planck length ( $l_p$ ).

The following argument is necessary to get the greatest value of A.

A displacement in a curved dimension can only be in proportion to a flattening. With reference to Fig. 29, the flattening is proportional to the ratio  $y/x$  and the greatest flattening occurs with the greatest possible value of this ratio. The value of  $y$  according to the radius of the dimension ( $R$ ) is given by:

$$y = \sqrt{R^2 - (R-x)^2} \quad (5)$$

and so:

$$y/x = \sqrt{R^2 - (R-x)^2}/x \quad (6)$$

If  $x_1 < x_2$ , we have that<sup>1</sup>:

$$\sqrt{R^2 - (R-x_1)^2}/x_1 > \sqrt{R^2 - (R-x_2)^2}/x_2 \quad (7)$$

This means that we have the greatest ratio  $y/x$  with the smallest value of  $x_1$ , which cannot be less than the Planck length ( $l_p$ ).

---

<sup>1</sup> In fact:

$$\sqrt{R^2 - R^2 + 2 R x_1 - x_1^2}/x_1 > \sqrt{R^2 - R^2 + 2 R x_2 - x_2^2}/x_2$$

$$\sqrt{2 R x_1/x_1^2 - x_1^2/x_1^2} > \sqrt{2 R x_2/x_2^2 - x_2^2/x_2^2}$$

$$\sqrt{2 R/x_1 - 1} > \sqrt{2 R/x_2 - 1}$$

$$2 R/x_1 > 2 R/x_2$$

$$1/x_1 > 1/x_2$$

$$x_1 < x_2$$

Therefore, with the greatest possible flattening:  $A = y = \sqrt{R^2 - (R - l_p)^2}$  and  $B = l_p$  (where  $l_p$  in this case means the length of Planck in the time dimension<sup>2</sup>) and the greatest ratio between the two catheti cannot be higher than:

$$A/B = \sqrt{R^2 - (R - l_p)^2} / l_p = \sqrt{R^2 - R^2 + 2 R l_p - l_p^2} / l_p = \sqrt{2 R / l_p - 1} \quad (8)$$

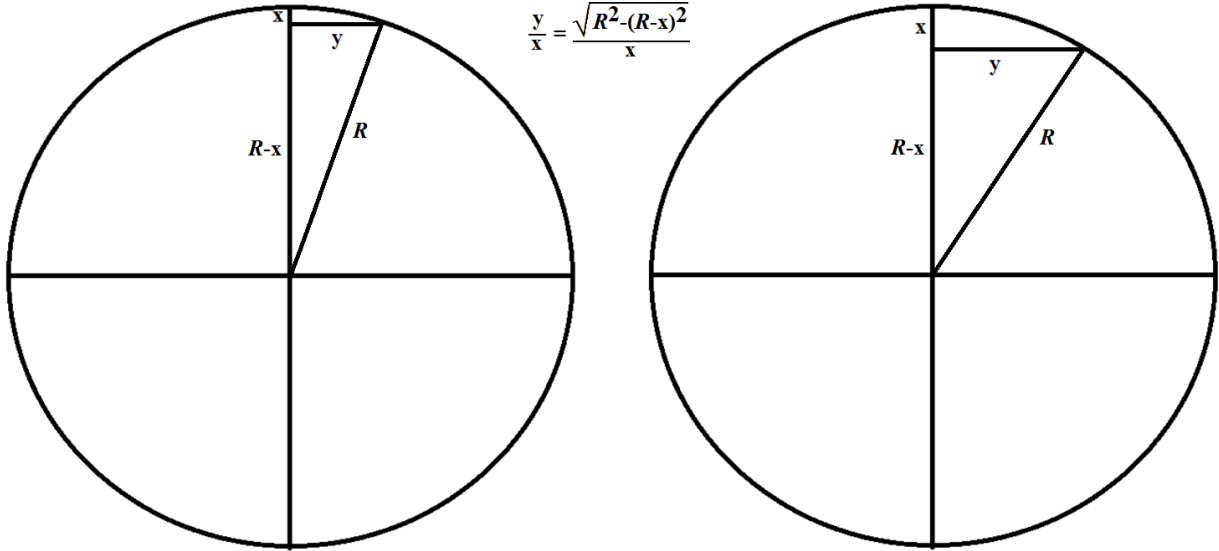

Figure 29 - By defining the measure of the flattening as the ratio  $y/x$ , this ratio is the greatest when  $x$  is the smallest possible.

This leads to the hypothesis that for a dimension  $Z$  with radius  $R_z$  (i.e., with diameter  $D_z = 2 R_z$ ), the maximum speed ( $c_z$ ) is in relation to the greatest possible ratio  $A/B$ :

$$c_z \propto \sqrt{D_z / l_p - 1} \quad (9)$$

If  $D_z$  is expressed in  $l_p$  and  $D_z \gg l_p$ , so that a unity may be disregarded, we have:

$$c_z \propto \sqrt{D_z} \quad (10)$$

or

$$c_z^2 \propto D_z \quad (11)$$

Similarly, it can be deduced that the maximum acceleration in a dimension  $Z$  ( $a_z$ ) will be equal to the maximum possible speed divided by  $l_p$ , and so:

$$a_z \propto \sqrt{D_z / l_p - 1} / l_p \quad (12)$$

If  $D_z$  is expressed in  $l_p$  and  $D_z \gg l_p$ , so that a unity may be disregarded, we have:

$$a_z \propto \sqrt{D_z} \quad (13)$$

i.e., the maximum acceleration is equal to the maximum speed.

This means that in any dimension the greatest possible velocity and the greatest possible acceleration are in relation to the curvature of the dimension, i.e., to its radius.

A very interesting consequence is that considering dimensions with less and less curvature (i.e., with  $R_z \rightarrow \infty$ ),  $A \rightarrow \infty$ , and the greatest ratio  $A/B$  (i.e.,  $c_z \rightarrow \infty$ ), and similarly  $a_z \rightarrow \infty$ .

A comment for the possible relationship between maximum velocity in our Spatial dimensions ( $c_s$ ; i.e., light speed,  $c$ ) and the curvature of these dimensions ( $1/R_s$ , assumed to be the same for the three

<sup>2</sup> It should not be confused with the Planck time unit defined as the time required for light to travel a distance of a Planck length in a vacuum.

Spatial dimensions) is that if the universe is expanding (that is, if  $R_s$  is increasing), this would imply an increase in the light speed. However, if space and time both increase at the same rate, the increase in  $c_s$  would be balanced by these increments and therefore  $c_s$  would remain constant in the measurements.

## 12. The black holes

As can be read in any good textbook of physics (e.g., [Walker 2014]), according to Newton's law of universal gravitation, a mass  $M$  with radius  $R$  (e.g., equal to that of the earth), for simplicity supposed as a non-rotating and with uniform density perfect sphere, determines an attractive force  $F$  for another mass  $m$  (for simplicity,  $m \ll M$ ), which varies depending on the inverse of the square of the distance  $r$  between the center of  $M$  and the point  $x$  of the position of  $m$  ( $F = G \cdot M \cdot m / r^2$ ).

If  $r < R$ , i.e., if  $x$  is inside  $M$ , the shells of  $M$  that are external to  $x$  do not determine attraction or repulsion on  $m$ , and the force of attraction on  $x$  is determined only by the parts of  $M$  with a radius equal to or less than  $r$  [Walker 2014]. Since the volume ( $V'$ ) of this inner part of  $M$  decreases in proportion to the cube of its radius  $R'$  ( $V' = 4/3\pi \cdot R'^3$ ) while the attraction decreases as an inverse function of the square of  $r$ , for a point  $x$  inside  $M$  the force of attraction, going towards the center, decreases proportionally to  $r$ , becoming null when  $r=0$ .

In short, the "gravitational force" ( $g$ ) determined by  $M$  on  $m$ :

- if  $r=R$  (i.e., when  $x$  is on the surface of  $M$ ), has its greatest value;
- if  $r>R$ , is reduced as a function of the inverse of the square of  $r$ ;
- if  $r<R$ , is linearly reduced in relation to  $r/R$  and becomes null when  $r=0$  (i.e., when  $x$  is at the center of  $M$ ).

These concepts are described in Fig. 30.

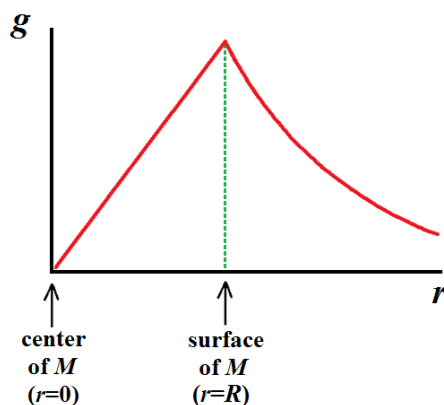

Figure 30 - According to the distance ( $r$ ) of a point  $x$  from the center of  $M$ ,  $g$  is zero at the center of  $M$ , grows linearly up to the surface of  $M$ , where it assumes its greatest value, and then decreases as a function of  $1/r^2$ .

Let us now consider a neutron star (N) with a mass just below the Tolman-Oppenheimer-Volkoff limit [Kalogera and Baym 1996], beyond which the gravitational force at the surface of N reaches the value of the light speed ( $c$ ) and therefore N becomes a black hole.

For such a body, the variation of  $g$  with values of  $r < R$  must have a behavior identical to that of much smaller bodies. Therefore, below the surface of N where  $g$  is almost equal to  $c$ , the value of  $g$  must decrease until it becomes zero at the center of N.

The unlikely hypothesis that the same rule of smaller bodies does not apply to N falls into a big contradiction that makes it unacceptable. In fact, if in relation to a lesser value of  $r$ ,  $g$  instead of decreasing would increase below the surface of N, so reaching the value of  $c$ , this would transform the whole star into a black hole and N could not exist.

It should also be noted that despite the enormous gravitational force, such as to press electrons and protons transforming them into neutrons, and to squeeze, for example, a mass of 1.4 solar masses in a radius on the order of 10 kilometers [Seeds and Backman 2009, p. 339], neutrons resist this force without difficulty.

Now let us consider a neutron star that exceeds the Tolman-Oppenheimer-Volkoff limit and thus becomes a black hole. The boundary of a black hole is the so-called event horizon and an external observer cannot have any direct knowledge of what happens inside that horizon.

According to the current view based on the formulas of general relativity, at the center of a black hole there is a singularity, a region in which the gravity and the curvature of space-time become infinite [Carroll 2004, p. 205]. For a non-rotating black hole, this singularity is a dot with zero volume, which contains all the mass of the black hole and so has infinite density [Carroll 2004, p. 252]. Stephen Hawking wrote: “The work that Roger Penrose and I did between 1965 and 1975 showed that, according to general relativity, there must be a singularity of infinite density and space-time curvature within a black hole.” [Hawking 1998, p. 90].

In a popular description of black holes: “According to the equations of general relativity the singularity is the place where matter has an infinite density, space is infinitely curved ... Back to black holes and their interior which, as defined by the event horizon, is completely empty space apart from the singularity in its center ...” [Al-Khalili 1999].

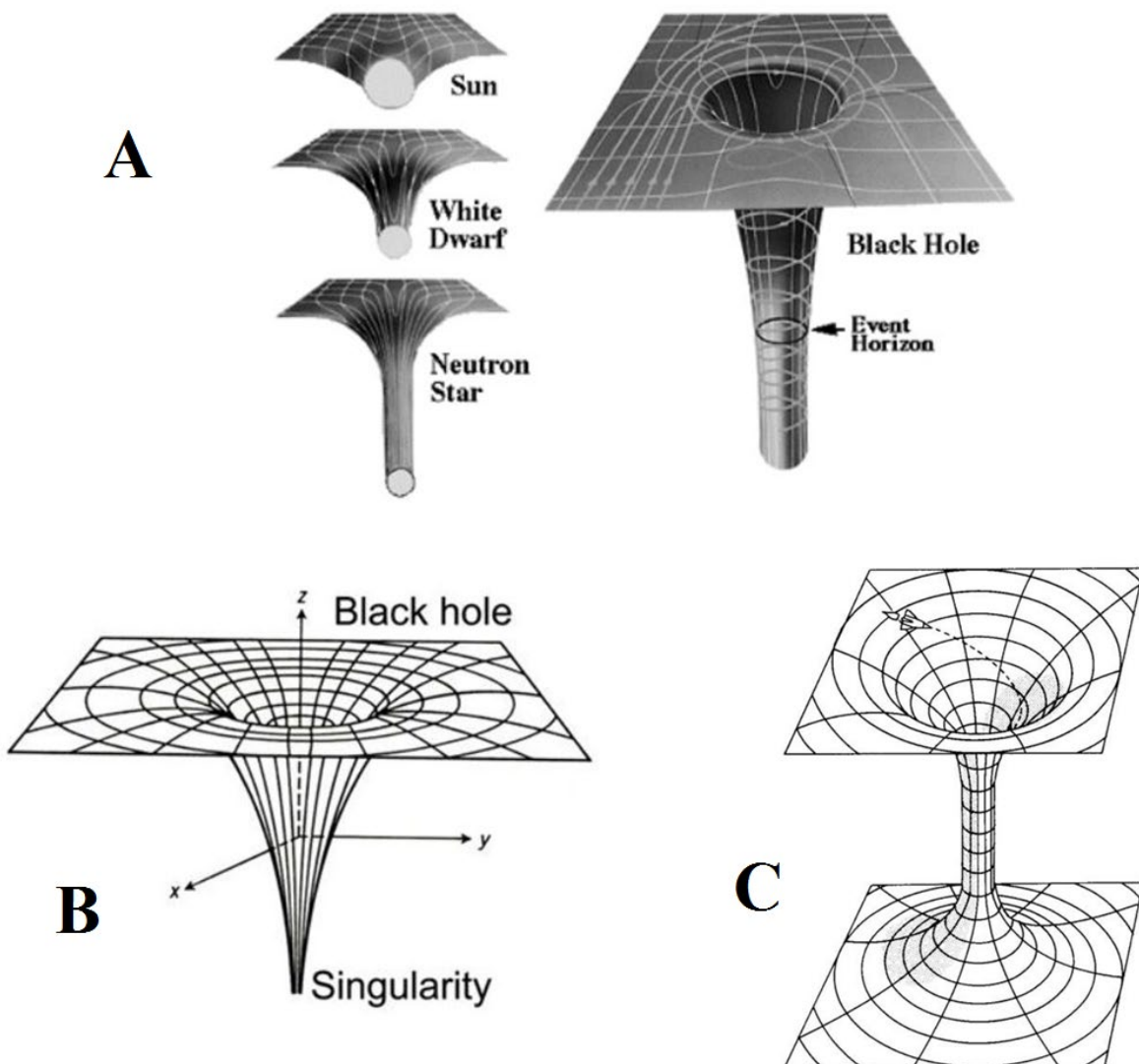

Figure 31 - A and B: two representations of a black hole and the singularity that would be at its center; C: a hypothetical tunnel between two parts of space-time caused by a singularity.

The idea of this singularity has stimulated imaginative hypotheses such as the existence of tunnels (“wormholes”) connecting the center of the black hole with other points in the universe: “... our

astronaut ... may be able to avoid hitting the singularity and instead falling through a 'wormhole' and come out in another region of the universe" [Hawking 1998, p. 91].

The existence of these wormholes, also known as Einstein-Rosen bridge, was hinted in 1916 [Flamm 1916], a few months after Schwarzschild published his solution for the gravitational field within a black hole [Schwarzschild 1916], and was clearly proposed by Albert Einstein and Nathan Rosen about twenty years later [Einstein and Rosen 1935].

Some popular representations of these ideas, which are always based on the questionable idea that a mass causes a hollow in a flat space and in our case a cavity with an infinite depth, are shown in Fig. 31.

Aside from these bold ideas, according to the current view, just past the event horizon and in direction of the center of the black hole, gravity continues to increase until it reaches an infinite value in the singularity where the density would also reach an infinite value. The variation of gravity predicted by this conception inside a black hole as a function of the distance  $r$  from the center is illustrated and summarized in Fig. 32, where it is compared with the variation of gravity in a neutron star just below the mass limit that would transform it into a black hole.

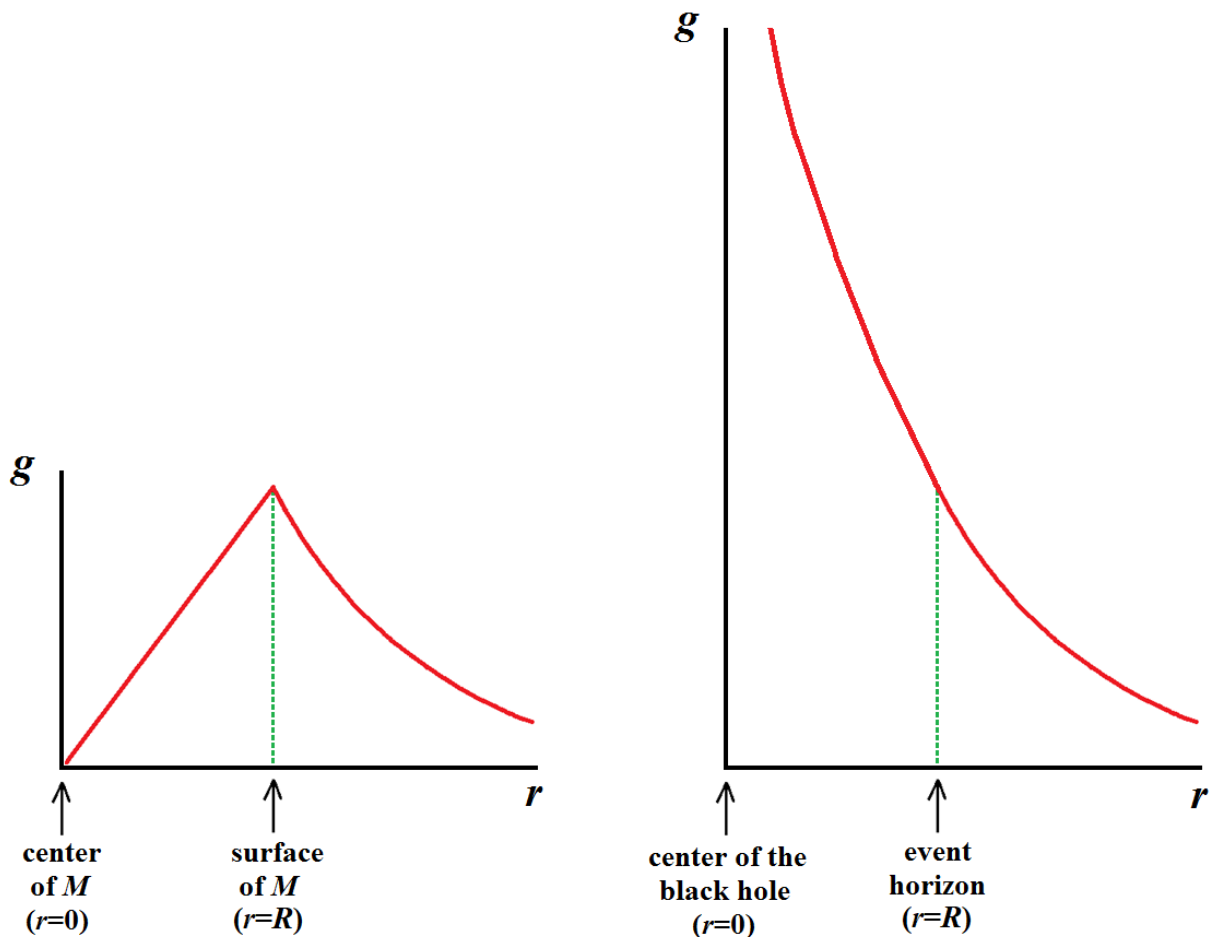

Figure 32 – On the left: variation of the gravity in function of the distance  $r$  from the center of  $M$  for any mass that is not a black hole. On the right: hypothetical variation of the gravity in function of  $r$  for a black hole.

Contrary to the accepted interpretation of the formulas of general relativity, it is not clear why exceeding the Tolman-Oppenheimer-Volkoff limit the variation of the gravity in function of  $r$  should totally change: while for the neutron star gravity drops from the greatest value at its surface to zero at its center, for a black hole gravity would increase with smaller values of  $r$ , becoming infinite at the center of the black hole.

Another contradiction arises from the fact that the mass would be concentrated all in the singularity, in which therefore the density would have infinite value and no atomic or subatomic structure could exist. This would result in the complete loss of information related to any particle fallen into the black hole. To solve the paradox of information loss caused by the black hole, it was proposed that information is held on the surface of event horizon (holographic principle [Susskind 1995]).

As an alternative hypothesis proposed in these pages, gravitational acceleration cannot go over light speed, gravity inside a black hole behaves in the same way as inside a neutron star, the event horizon is exactly on neutron star surface, where gravity is the greatest possible, and gravity decreases going towards the center of the black hole. There is no “singularity” with infinite gravity and density at the center of the black hole, where on the contrary there is zero gravity. Afterwards, if for additions from the outside, the mass inside the black hole increases, the number of neutrons and the radius of their total mass increase proportionally and the event horizon is always exactly at the surface of the neutron star.

The radical difference between the two interpretations arises from the completely different ways in which the distortion of space-time is hypothesized to modify the geodesics, so determining deviations that are seen as “gravitational force”. For the current interpretation, in absence of “masses”, the dimensions that constitute the space (Spatial dimensions) are flat and the presence of a “mass” determines a distortion of the space that causes the “gravitational force”. Furthermore, there is no limit to the degree of space distortion and therefore a singularity, i.e., a point with infinite distortion and consequently with infinite “gravity”, would be theoretically admissible.

On the contrary, for the alternative interpretation, it is assumed that in absence of “masses” the Spatial or Newtonian dimensions are curved and that a mass determines a flattening of their curvatures. The greatest possible flattening is when there is the greatest ratio A/B (s. the discussion of the previous section). A greater flattening is impossible and therefore an infinite “gravitational force” is impossible. Moreover, about the hypothesis of singularities with infinite density, this would mean postulating that the Weak, Strong and quark color “forces” can be overcome by the “gravitational force”, which appears impossible at the atomic and subatomic distances at which such “forces” act. It could be argued that there is no evidence that Spatial dimensions are curved. However, if it is true that our sub-universe arose from the Big Bang of a tiny initial bubble and that it is still rapidly expanding, this implies that the Spatial dimensions are curved from the origin and have expanded and continue to expand like an inflating balloon.

It should be emphasized that when Einstein proposed the theory of general relativity there was no concept of the Big Bang and the expansion of the Universe from a very small initial bubble with the implication that the Spatial dimensions and any other possible dimension are curved. Furthermore, the formulas proposed by Einstein for the curvature of a flat space by the effect of a mass have never been adapted to the different idea of a curved space flattened by a mass.

### 13. Heisenberg’s uncertainty principle and its possible reformulation

The Heisenberg’s uncertainty principle [Heisenberg 1927] asserts “a fundamental limit to the precision with which certain pairs of physical properties of a particle, known as complementary variable, such as position  $x$  and momentum  $p$ , can be known simultaneously.” [Kisak 2016, p. 282]

For example:

$$\Delta x \cdot \Delta p \geq \hbar/2 \tag{14}$$

that is to say the uncertainty relative to the position of a particle multiplied by the uncertainty relative to its momentum is not less than half of the reduced Planck constant ( $\hbar$ ).

The same concept was expressed by the formula:

$$\sigma_x \cdot \sigma_p \geq \hbar/2 \text{ [Kennard 1927]} \tag{15}$$

where  $\sigma_x$  and  $\sigma_p$  are the standard deviation of position and momentum, respectively.



This principle presupposes the existence of “particles” that move in the space.

However:

- if the term “simple particle” is only an approximate and potentially misleading description of a wave (or more precisely of a flattening in a dimension caused by the double oscillation of a segment of the dimension; and so the term “complex particle” indicates an associated group of waves), that is to say that no “particle” is conceived as an entity distinct from the dimension (or dimensions) in which the wave (or the group of waves) moves;
- if the detection of a value of the “particle” is only the measurement of a wave parameter that provides a value relative to something, the “particle”, which is postulated to exist;

it follows that the uncertainty principle only describes the impossibility of precise measurements on something that is assumed wrongly to exist and so interprets a phenomenon differently from what it is.

If what said in the preceding sections is true, no particle (or set of particles) exists. There are only flattening, or associated groups of flattening, caused by double oscillations of segments of dimensions, which can be described mathematically as waves. Their description and measurement as “particles” are useful only to the extent that it is clear that particles as distinct entities do not exist and that the measurements describe a reality different from that of a particle understood as an entity in its own right.

For example, it is known that if a series, temporally distinct, of photons (i.e., a series of electromagnetic waves, only one of them passing through a section  $S$  per unit of time) crosses two thin slits and then falls on a detecting surface, the wave interferes with itself determining interference fringes on the detection surface. Interference, even of a single photon with itself, is possible because photons are waves and not particles.

When each electromagnetic wave reaches the detector surface, which is a spatially discrete group of detectors (each of them consisting of other waves or groups of waves), if the energy contained in a single photon is able to activate only a single detector, as a result of its quantization it cannot be divided into several detectors. Depending on the modification of the shape of the wave caused by the slits and on the aforementioned interference, only one of the detectors will be activated for each single photon, determining gradually the interference figure. The fact that only a single detector is activated each time does not imply that the photon is some kind of object that is present simultaneously on the whole surface of the wave with a probability for each point proportional to the height of the wave in that point.

Any description of the physical world as “particles” that aggregate, move, hit, etc. is an unfaithful description of what actually happens. If this description is used as a means to simplify and make a description less difficult, the simplification is admissible only if one never forgets that this is merely a useful simplification and not a faithful description.

Therefore, the uncertainty principle arises from the implicit wrong attribution of existence to entities, the “particles”, which do not exist as such.

Hawking is very clear about this: “The uncertainty principle of quantum mechanics implies that certain pairs of quantities, such as the position and velocity of a particle, cannot both be predicted with complete accuracy. Quantum mechanics deals with this situation via a class of quantum theories in which particles don’t have well defined positions and velocities but are represented by a wave. These quantum theories are deterministic in the sense that they give laws for the evolution of the wave with time. Thus, if one knows the wave at one time, one can calculate it at any other time, The unpredictable, random element comes in only when we try to interpret the wave in terms of the positions and velocities of particles. But maybe that is our mistake: maybe there are no particle positions and velocities, but only waves. It is just that we try to fit the waves to our preconceived ideas of positions and velocities. The resulting mismatch is the cause of the apparent unpredictability.” [Hawking 1988, pp. 188-189]

In short, instead of particles we have only and always waves, or rather double oscillations, which we can describe by formulas without being able to specify for any instant  $t$  the precise position of the

points of the oscillating segment of the dimension. In fact, in order to know this position, we can only use other waves of which we also have only partial knowledge and furthermore any attempt at observation involves a modification of the wave under study. For example, if we had complete knowledge of an electromagnetic wave, we could predict with absolute certainty which of the possible receptors will be activated. On the contrary, having only knowledge of the shape of the wave, which we represent, in a misleading way, as the probabilistic presence of non-existent particles defined as photons, we will only be able to predict in a probabilistic way which receptor will be activated.

Let's explore these concepts.

The “uncertainty principle” as proposed by Heisenberg, and by others who have followed his approach, is undermined at the base because it postulates the existence of “particles” which, on the contrary, are only waves or wave complexes.

Even the representation of a particle as the coexistence of a body and a wave, which manifests itself in one state or another depending on the type of investigation used, is false and misleading.

By considering Heisenberg's principle simply as the impossibility of perfectly determining the characteristics of fictitious entities such as “particles”, what is it possible to say about the determination or indeterminacy of any wave, or wave complex?

Let us consider a simple “particle”, composed by definition of a single wave, described as a double oscillation. An example of simple “particle” is a photon, i.e., an electromagnetic wave.

It is easy to know the frequency and amplitude of this type of wave. However, for a complete knowledge it is also necessary to know, in a defined instant  $t$ , the position of the wave with respect to the rotation axis.

To investigate this position, something that must be used as a “probe” is necessary. However, any “probe” will necessarily be composed of other simple “particles” or aggregates of simple “particles” (complex “particle”) or even sets of several particles, of which we also do not have perfect knowledge. Even if we wanted to build a “probe” *ad hoc* of which there is perfect knowledge, this is impossible because it would be necessary to use instruments composed of other “particles” of which we do not have perfect knowledge.

Not having perfect knowledge of any possible “probe”, we will never be able to obtain perfect knowledge of any elementary “particle”, and even more of any complex “particle”.

This impossibility is independent of the subsequent likely modification of the “particle” under exam as a consequence of the observation.

Therefore, with regard to the innumerable existing simple or complex “particles”, we are unable to have perfect knowledge of even a single “particle” and not even for the single instant that precedes the changes determined by the observation.

As for the knowledge by an intelligent being, the universe in every “particle”, or smallest part, or possible subdivision, or in its totality, is therefore unknowable in a perfect way. Likewise, a perfect description of the future or past of any part of the universe is impossible.

This can be described as total indeterminacy for the perfect knowledge by a cognitive intelligence.

However, apart from this impossible knowledge, each wave is perfectly determined in every detail and so it is also perfectly determined in its interactions with every other wave in both directions of the Time dimension.

So, who was right then between Einstein who maintained a world that was always completely deterministic (“God does not play dice with the universe” [Einstein 1971]) and Heisenberg for whom everything was indeterminate and probabilistic? In some ways, both theses are correct. If “particles” are only simplified and approximate descriptions of waves or groups of waves, we could say that the perfect knowledge of the state of these waves at any moment would make the world totally deterministic for the knowledge by an intelligent being, but that the impossibility of such knowledge also makes the world completely probabilistic in the same terms of knowledge.

In the context of these arguments, what happens to Schrödinger's famous cat [Schrödinger 1935], whose life or death depends on the non-decay or decay of an atom X? Since its fate depends on events - the non-decay or decay of an atom - of which the two probabilities coexist, the cat would be in a

state of quantum superposition where the conditions of “live cat” and “dead cat” would exist at the same time [Moring 2001].

However, by eliminating the preconception of the existence of “particles” as distinct entity, the fate of the cat depends only on the interaction of the waves in atom X. We cannot absolutely know perfectly the waves of this atom but, apart from our ignorance, the behavior of the waves is completely deterministic and the fate of the cat is only one, although unknown to us. Therefore, the superposition of several states, including that of the famous cat, exists only in our preconception that there are “particles” for which there is no precise position but only a probability distribution of the position.

Even more groundless, unnecessary, and wholly imaginative is the idea that when we try to know the position of a “particle” a new universe is created [Everett et al. 1973].

#### 14. Rotation of a segment of a dimension

A double asynchronous oscillation of a segment of a rope (schematic representation of a segment of a one-dimensional space) is necessary to have a rotation, which must be understood as the rotation of the segment around the position of the rope at rest and not as a twist of the rope around itself.

Equally, in a three-dimensional space, the double asynchronous oscillation of a segment of any Spatial or Newtonian dimension (N, N' and N'', or simply N) originates a clockwise or counter-clockwise rotation, arbitrarily defined as positive or negative rotation. This implies that, in order to rotate, a segment of a one-dimensional space requires two further dimensions plus the Time dimension.

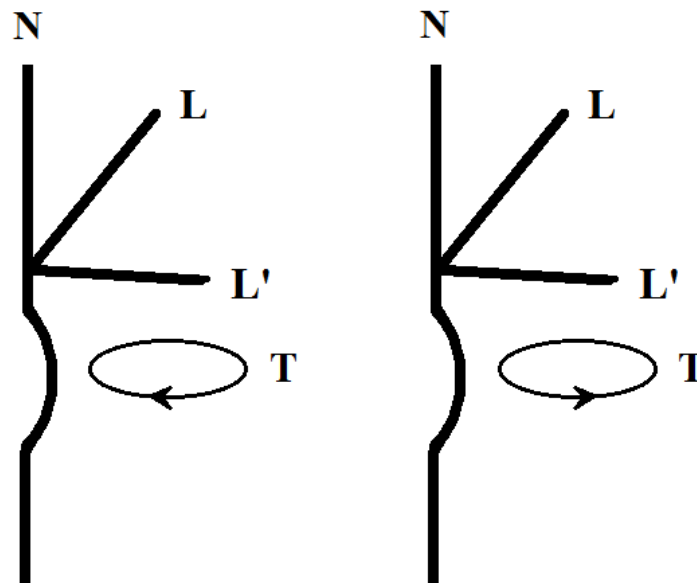

Figure 33 - On the left, a segment of the Spatial or Newtonian dimension N, seen from the top of the image, rotates clockwise around the Spatial dimension N in the dimensions L and L', while on the right rotates counter-clockwise. The two types of rotations are defined arbitrarily as positive and negative, respectively. Spatial dimension N is a curved dimension, but the curvature is too much small for the scale of the image. Moreover, the curve of the rotating segment has been markedly exaggerated to make it visible. L and L' are two dimensions with zero or almost zero curvature.

It might seem obvious and without any need for investigation or discussion that these two further dimensions are the other two of the three Newtonian dimensions of which we have continuous direct experience. However, for reasons that will be expressed in the next section, it is necessary that these two additional dimensions have zero or very small curvature and so cannot be any of the usual Newtonian dimensions. Provisionally, it is here hypothesized that these two additional dimensions,

defined as Entanglement 1 (L) and Entanglement 2 (L'), are with curvatures that are null or very small compared with that of the Newtonian dimensions (Fig. 33).

### 15. Flattening and electromagnetic waves

When the energy of an electron varies, in quantized steps, it emits or absorbs energy through electromagnetic waves (also described as photons).

The change in energy of an electron does not modify its electric charge, but is related to the variation of its speed and mass. How is it possible that there is mass variation simultaneously with the emission (or absorption) of electromagnetic waves that have no mass?

A possible explanation is the following.

Let us assume that the set of waves briefly defined as electron includes three groups of oscillations/rotations that are distinct for each of the three Spatial dimensions and that a greater speed in each of the three Spatial dimensions involves:

- higher frequency of oscillations for the segments of the Spatial dimensions;
- shortening along the directions of movement on the Spatial dimensions;
- time compression (time runs slower for an object with higher speed);
- greater mass/energy of the electron,

while a reduction in the speed implies:

- reduction of the frequency of oscillations;
- stretching along the directions of movement;
- time expansion;
- lower mass/energy of the electron,

and the two cases (acceleration or deceleration) imply a transfer of the energy difference from or to electromagnetic waves.

Let us now assume that each of the three rotations in the three distinct Spatial dimensions occurs in two dimensions that are different from the Spatial ones and have a zero or at least infinitesimal curvature. In the variation of electronic energy/mass the difference is emitted (or absorbed) through double oscillations of these two non-spatial dimensions with energy as a function of the frequency of the oscillations. Since these two non-spatial dimensions have no curvature (or negligible curvature), their oscillation causes no mass variation (or negligible mass variation).

This hypothesis implies several things:

- The double oscillations, both for the Spatial dimensions and for any other dimension having curvature, always imply that they occur in the two dimensions with zero or infinitesimal curvature;
- An electromagnetic wave is commonly defined as a double oscillation that propagates in space but it is never defined what oscillates. The description that the electromagnetic wave is the oscillation of a magnetic field and of an electric field describes the effects but not the nature of what oscillates. According to the above said hypothesis, we now have that an electromagnetic wave is a double oscillation in two dimensions with zero or almost zero curvature;
- Since these oscillations propagate in space but are not oscillations of segments of space, they have no mass and cannot increase their mass in relation to increasing speed;
- As they have no mass, their speed in vacuum is equal to the maximum speed relative to the maximum possible flattening in the spatial dimensions, that is the speed of light;
- As the two aforementioned non-spatial dimensions, defined as Entanglement 1 dimension (L) and Entanglement 2 dimension (L'), have a curvature that is zero or almost zero, the maximum speed in these dimensions is not that of light but is much greater the less the curvature (or the greater the radius) of these dimensions is, i.e.: with  $R_{L \rightarrow \infty}$ ,  $c_{L \rightarrow \infty}$ .
- Phenomena generally defined as “entanglement” phenomena require either action at a distance or a speed that is infinite (or at least much greater than light speed). The aforementioned non-spatial dimensions could be the key to explaining entanglement phenomena and precisely for this reason they have been defined before as Entanglement 1 and 2;

- Let us now consider a double oscillation that runs in the void with the speed of light ( $c$ ), having a wavelength  $\lambda$  and so a frequency  $f$  equal to  $c/\lambda$ , and which we suppose asynchronous with a phase shift between the two oscillations of  $90^\circ$  (s. Fig. 34). Due to the overall movement of the two oscillations, any point (P) of one of the two oscillations, in a section of the oscillation axis equal to  $\lambda$ , makes a complete revolution around the axis with a path equal to  $2\pi r$ , where  $r=\lambda/4$  and so  $2\pi r = \pi\lambda/2$ , and at the same time it moves by a distance equal to  $\lambda$ . The overall path will therefore be equal to  $\lambda+\pi\lambda/2$ . As the double oscillation, referring to a point Q on the axis of oscillation, at the same time has moved by a distance equal to  $\lambda$ , the ratio between the path of P and that of Q (i.e., of the entire double oscillation) is equal to  $1+\pi/2 = 2.570796$ . Therefore, if the double oscillation moves with speed  $c$ , the point P moves with a speed equal to  $2.570796 c = 770.705.46$  km/sec. This ratio is valid whatever the values of  $\lambda$ , i.e., whatever the frequency  $f$  of the double oscillation (the values  $\lambda$  and  $f$  are not present in the aforementioned formula of the ratio). The velocity of any point of an oscillation is clearly greater than the maximum velocity ( $c$ ) of a body moving in the spatial dimensions. This is possible only if it is admitted that the oscillations occur in dimensions in which the maximum speed is greater than  $c$ .
- As the dimensions L and L' need to oscillate another dimension, the Time dimension (T), to explain why the oscillations occur for L and L', and not, e.g., for L and T with L' in place of the T dimension, it is necessary a difference between a common characteristic of L and L' and that of time. The only difference that can exist between two dimensions is in the radii of the curvatures. Therefore, the Time dimension should have a minimal curvature (i.e., not zero or almost zero). Moreover, the increase of the oscillation frequency would require more and more energy. This would justify the energy of electromagnetic waves and their increasing energy in relation to frequency.

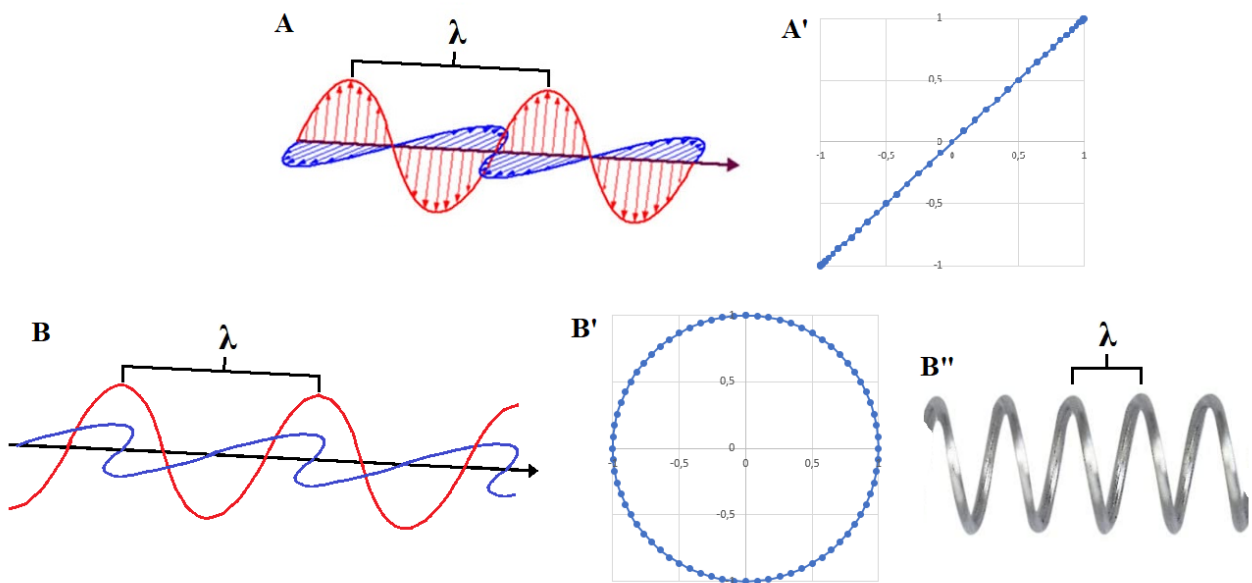

Figure 34 - A: Scheme of a synchronous double oscillation (or wave); A': The movement of a point of the wave represented in A seen from the front; B: Diagram of an asynchronous double oscillation with phase shift between the two oscillations of  $90^\circ$ ; B': The movement of a point (P) of the wave represented in B seen from the front. The value of  $r$  (radius of the movement of P seen from the front) is equal to  $\lambda/4$ ; B'': The schematic movement of P in a three-dimensional view is similar to that of the coil of a spring.

- According to the theory of relativity, a body with speed  $v$ , as its speed increases, reduces its length in the direction of movement, tending to an infinitely short length as  $v$  approaches light speed ( $c$ ). Electromagnetic waves are a blatant exception to this law: even though – by definition - they have

a velocity equal to  $c$  in a vacuum, they show no shortening in the direction of movement. This could be explained by the fact that in the electromagnetic waves there are no segments of the Spatial dimensions and therefore, as the aforementioned law should apply only to the Spatial dimensions, there is no flattening in the direction of movement.

Another representation of electromagnetic waves is offered by Fig. 35. In it, we see the succession of three series of regularly spaced waves (each wave defined as a photon), which are distinct from each other for the wavelength, i.e., for frequency (which is decreasing going from top to bottom in the image).

The larger size of photons with longer wavelengths might lead one to believe that the bottom series is the one with more energy, but, on the contrary, it is the top series, with smaller size and higher frequency, which is more energetic. In short, the energy of electromagnetic waves is related to the frequency, that is to the Time dimension (T), and not to the size of the photon, i.e., to the two non-Newtonian dimensions L and L' in which the wave oscillates and which can mistakenly be understood as Newtonian dimensions.

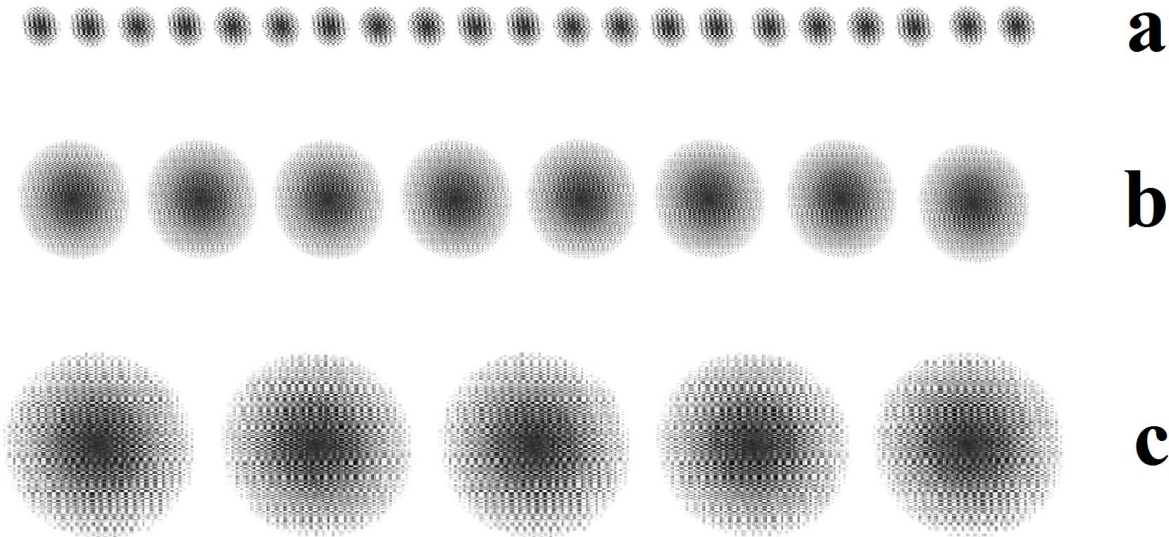

Figure 35 – Three series of electromagnetic waves (photons) that move in space, with energy that decreases going from the top (higher frequency, shorter wavelength) downwards (lower frequency, longer wavelength).

**16. Spatial and temporal changes caused by a greater velocity or acceleration**

According to Einsteinian general relativity, for a body that goes at a certain velocity or accelerates in a N direction (any of the three Newtonian or Spatial dimensions), there is a shortening of its length on N direction, an increase in mass and a slowing down of the time, phenomena quantitatively described by Lorentz’s transformation equations, up to a maximum that coincides with the speed of light.

How could we describe by images what happens to any elementary or non-elementary “particle” as it runs at a greater velocity or accelerates?

An elementary particle is here described as the flattening of a section of a curved dimension (e.g., N), caused by the rotation in two dimensions that have null or infinitesimal curvature, Entanglement 1 (L) and Entanglement 2 (L’), and in the Time (T) dimension, determined by oscillations with width equal to the quantum unit of length (length of Planck) or a multiple of it (Fig. 36).

Let us imagine a particle that runs along N with less or greater speed, or that is in acceleration.

As the speed ( $s$ ) increases the particle increases its mass/energy by assuming quantum units of the dimension N and this would explain how its length is reduced in the direction of N. The increase in speed also involves the progressive assumption of time quanta, which would explain how the time flows more slowly for an accelerated body or anyway having greater speed than another body.

If a particle accelerates and then decelerates returning to the original speed, in the second phase it loses quantum units of the dimension N and of Time dimension and returns to length (in the direction of N), mass and time flow at the moment of the start of acceleration. However, the time spent more slowly after the beginning of acceleration and before the end of deceleration remains, for example, in the measurements of a clock that has been accelerated and then decelerated (or for any other instrument, organism or phenomenon whose time can be evaluated).

The accumulation of quanta in relation to the speed is not linear and follows the dynamics of Lorentz's transformation equations. So, at low velocities ( $s \ll c$ ), the variations of mass, length and time are very small, while they increase progressively as  $s$  becomes equal to consistent fractions of light speed, and then increase exponentially when  $s \approx c$ .

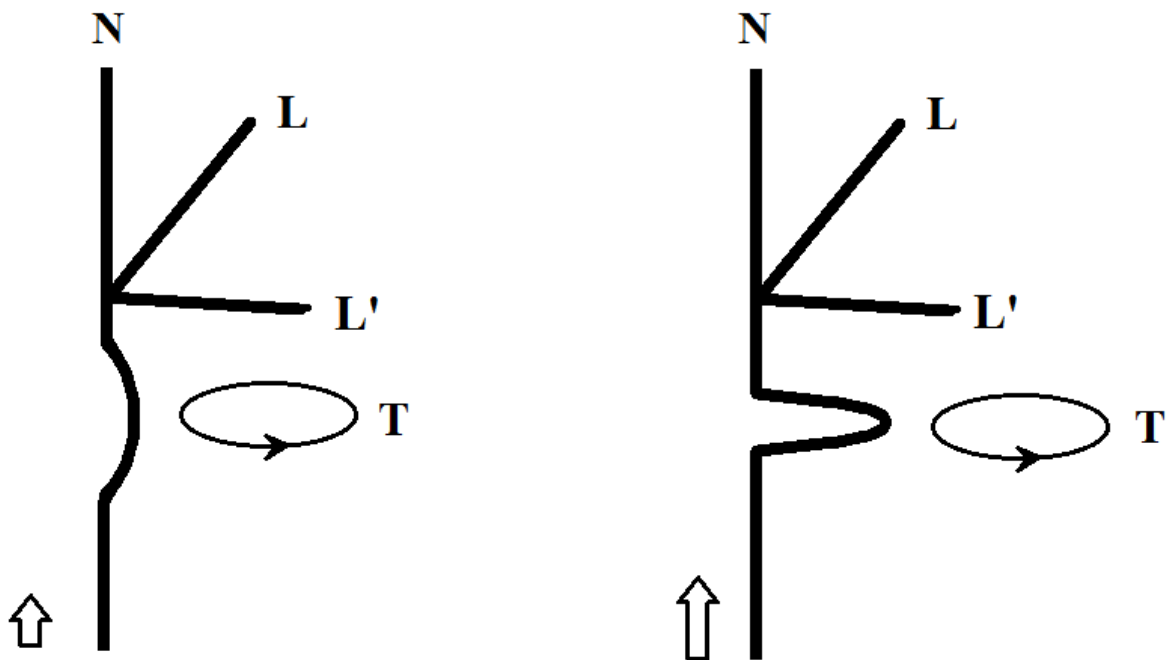

Figure 36 - On the left, a segment of dimension N rotates by a double oscillation around the axis of N in the L and L' dimensions, which are non-curved or with minimal curvature. The curvature is very slight for the scale of the image and cannot be visible, while the curve of the rotating segment has been markedly exaggerated. The flattening determined by the rotation and defined as “particle”, moves in the direction indicated by the arrow. On the right, as the particle increases its velocity (bigger arrow), it assumes quanta of the dimensions N and T (indicated by the growing bulge). The assumption of quanta of the two dimensions means for the particle a shortening of its length according to the direction of N, an increase of its mass/energy, and a slowing down of the passage of time in comparison with other particles with less speed.

### 17. Description of a body rotating with uniform speed around another body

Let us consider a body with mass (for example, a satellite) that rotates with uniform velocity around another body (the earth). In the ordinary direction of time, the movement of the body can be described as the effect of two vectors: the first tends to move the body away from the earth, the second is the “force of gravity” that pushes the body towards the earth. If in the description we invert the time coordinates of reference, we will have that the first vector reverses its direction while the second vector still points towards the earth.

The apparent paradox is explained by considering that the “gravity force” does not exist as such and that what we describe with this name is the effect of the curvature of the geodesics determined by the masses, which is independent of the direction of the arrow of time.

It should also be considered that, in relation to the gradual change in the direction of the movement of the body, the same rotates but certainly the three spatial dimensions do not rotate. Consequently, in order to maintain the shortening of the body along the direction of movement, the oscillations that constitute its “particles” along the three Spatial dimensions must be suitably modified, with quantized transfers of energy between the three dimensions, obviously without changes of the total energy.

### **18. Description of a body that is attracted by another body**

Now, in accordance with the concepts of Einstein’s general relativity, let us consider a body that, starting from a condition of zero velocity with respect to the earth, due to the aforementioned distortions of the geodesics in the Spatial dimensions, falls towards the earth from the height  $h_1$  to the lower height  $h_2$  in a time  $t$ , and acquires at the end of  $t$  the speed  $v_f$ . Let us try to describe the same phenomenon by inverting the time coordinates of reference.

By inverting the vector of the velocity  $v_f$ , this is continuously braked by the effects of the geodesics until the speed is zeroed at time 0.

Moreover, we must consider that the body in passing from  $h_1$  to  $h_2$  accelerates and therefore increases its velocity and mass, shortens its length in the direction of acceleration and assumes quanta of time (i.e., time slides more slowly for the body). In the inversion of time coordinates, the body reverses the direction of its fall and progressively reduces its mass, extend its length in the direction of deceleration and loses quanta of time. When the body has exactly returned to the initial time, all of its initial conditions are restored.

### **19. The entanglement**

Entangled phenomena occur when, for a pair (or a group) of particles generated in opportune ways, the state of each of them cannot be known without conditioning instantly the state of the others, even if a large distance separate them. So, for entangled particles, when measurements of properties such as rotation, polarization, position, and momentum are performed, a perfect instant correlation is found between them.

As the correlation appeared instantaneous, or in any case occurred with a speed much greater than light speed, Einstein and others considered this type of phenomena as impossible, because they violated the local realism accepted interpretation of causality, and Einstein referred to them as “spooky action at a distance” (“spukhafte Fernwirkung”) [Einstein 1971], arguing that quantum mechanics was somehow incomplete.

The “entanglement” phenomena presuppose one between two entirely alternative types of explanation:

- or that there is a relationship at a distance between a pair (or a group) of “particles”;
- or that there is something moving between the “particles” with much greater speed than light speed.

However, rigorous (“loophole-free”) Bell tests have shown that a speed at least 10,000 times greater than that of light would be necessary to justify a direct communication between the entangled “particles” that could explain entanglement [Matson 2012; Juan et al. 2013].

A dimension with null or almost null curvature (so, with  $c_X=\infty$  or with  $c_X\rightarrow\infty$ , respectively) would make the second hypothesis admissible.

This would mean that, for example in the generation of a pair of entangled particles, the division into two particles is only apparent and that the oscillations constituting the two particles are still connected in the dimensions L and L', which do not have the limit of light speed due to their null or almost null curvature.



## 20. The anthropic principle

There are some physical constants that are defined as fundamental because not derivable from other constants. For the current theories, the origin of the numerical values of these constants is unknown: "... gradually we have identified a collection of mysterious numbers which lie at the root of the consistency of experience. These are the constants of Nature. They give the Universe its distinctive character and distinguish it from others we might imagine. They capture at once our greatest knowledge and our greatest ignorance about the Universe. For, while we measure them to ever greater precision, fashion our fundamental standards of mass and time around their invariance, we cannot explain their values. We have never explained the numerical value of any of the constants of Nature. We have discovered new ones, linked old ones, and understood their crucial role in making things the way they are, but the reason for their values remains a deeply hidden secret. To search it out we will need to unpick the most fundamental theory of the laws of Nature, to discover if the constants that define them are fixed and framed by some overarching logical consistency or whether chance still has a role to play." [Barrow 2002, Preface].

Yet, it is known that even small differences of their values would change radically all known phenomena. If, for example, one or more fundamental constants had a different value, no stars, galaxies, planets would have formed and life as we know it would have been impossible [Barrow 2002].

The extraordinary coincidence between the existence of the universe as we know it, including the existence of living beings and of a species self-defined as intelligent, is called the "anthropic principle" [Carter 1974]. This principle can be expressed in various ways, among which there are two main types of definition:

### A) *Weak anthropic principle*

- "[W]e must be prepared to take account of the fact that our location in the universe is *necessarily* privileged to the extent of being compatible with our existence as observers." [Carter 1974]
- "The observed values of all physical and cosmological quantities are not equally probable but they take on values restricted by the requirement that there exist sites where carbon-based life can evolve and by the requirements that the universe be old enough for it to have already done so." [Barrow and Tipler 1988]

### B) *Strong anthropic principle*

- "[T]he universe (and hence the fundamental parameters on which it depends) must be such as to admit the creation of observers within it at some stage. To paraphrase Descartes, *cogito ergo mundus talis est.*" [Carter 1974]
- "The Universe must have those properties which allow life to develop within it at some stage in its history." [Barrow and Tipler 1988]

The main explanations of the anthropic principle are substantially of two types:

- 1) The universe was created by a Designer who defined carefully and specifically all the fundamental constants so that everything that exists, including life and intelligence, could develop;
- 2) There are many or infinite universes with different fundamental constants and our universe exists as it is and we can describe it precisely because the fundamental constants have certain values.

After these premises and in support of the second type of explanation, if the values of all the fundamental physical constants, and therefore all that follows from it, derive from the number of dimensions and their curvatures, the characteristics of any sub-universe, our sub-universe included, derive solely from the random assortment of the dimensions with various curvatures that constitute each of the sub-universes.

With the hypothesis that there are infinite bubbles (or sub-universes), each consisting of a finite number of dimensions with various curvatures, it is easy to assume that for most sub-universes the

derived fundamental physical constants do not allow the formation and existence of the universe as we know it (life and intelligence included) or of something equivalent that allow life and intelligence. If we exist and therefore can appreciate the extraordinary combination of fundamental constants of our universe, it is precisely because the particular combination of various dimensions of our sub-universe is such that it determines the aforementioned extraordinary results. On the other hand, if this was not the case for this sub-universe, we could not exist and so we could not detect a combination that was unsuitable for developing protons, stars, life, intelligence and everything we know. The same consideration applies to any possible sub-universe.

## **21. Origin of the bubbles or sub-universes**

At the origin of our sub-universe there is the common idea, supported by many arguments and facts, that there was an infinite thickening of space, energy or other that afterwards has expanded, to an explosive extent in the first few moments, and continues to expand, constituting the so-called Big Bang.

No hypothesis is suggested here about the origin of bubbles or sub-universes.

Among other possible related questions: if the Time dimension is one of the dimensions of our sub-universe and the origin of the sub-universe somehow implies a unique status for the Time dimension, how is this privileged condition justified or what is the explanation that nullifies this apparent privileged condition?

An analogy has been observed between the infinite thickening in the first moment of the Big-Bang and the hypothetical singularity at the center of each black hole and it has been proposed that each singularity could be the origin of a further universe. However, if this were the case, it would be necessary to explain how the formation of a new universe from the singularity does not determine the emptying of the singularity and therefore the disappearance of the black hole.

## **22. The Time dimension**

If the “symmetry postulate” is true for any dimension, then for the Time dimension too no difference is possible between the displacement in one direction (arbitrarily defined as forward or in the direction of the future) and the displacement in the opposite direction (arbitrarily defined as backward or in the direction of the past).

This also implies that as any physical phenomenon can equally exist, qualitatively and quantitatively, in each of the two directions of any dimension, any formula, or set of formulas, describing a phenomenon must also have equal validity in each of the two directions of the Time dimension.

For some types of phenomena this is self-evident even with simple mental simulations.

Let us imagine a “body” (an elementary or complex “particle”, or any aggregate of “particles”, which for brevity is implied to consist only of waves), which by inertial motion, starting from point  $x_1$  at time  $t_1$ , reaches point  $x_2$  at time  $t_2$ .

By inverting the time coordinates of reference (not the time!), it is possible to say with certainty that the body goes from point  $x_2$  at time  $t_2$  to point  $x_1$  at time  $t_1$ . This trivial example shows that the inertial displacement of a body, in the two different descriptions in which we use opposite time coordinates of reference, is completely indifferent to the time direction. Similarly, an argument can be made for  $n$  bodies with inertial motion bumping into each other. The displacements of one or more bodies, and the changes in their directions in space as a result of collisions, can be described by formulas that retain their full validity even reversing the time coordinates of reference.

In these simple mental experiments, there is always an unspoken assumption, perhaps because it is unconsciously regarded as a “natural” fact for any body and therefore without exception: all bodies, although they have no assumed limitation for their movements in the three Spatial dimensions, as far as the Time dimension is concerned, always move in the forward direction. Consequently, since all bodies move in the same direction of Time dimension, a collision between two bodies may change

their inertial motions in the Spatial dimensions but cannot in any way change their motion from forward to backward in the Time dimension.

It would be quite different with a body A that, in the usual time coordinates of reference, moves backward in the Time dimension. By bumping with such a body another body B, this could be pushed not only in different directions in the Spatial dimensions but also in a backward direction in the Time dimension.

Having no available body with backward motion, let us now consider whether by using a “force” we can obtain a body with such a characteristic.

First, let us consider two bodies with inertial motion whose displacement is modified by the gravitational “force”.

A body A has an inertial motion that leads it to pass close to a body B (assumed for simplicity to be stationary and with much greater mass than A). Clearly, due to the gravitational “force”, the direction of the motion of A is deflected toward B. By reversing the time coordinates of reference, the direction of the inertial motion of A is inverted, while the gravitational “force”, without any reversal, deflects the body A toward B with equal intensity (Fig. 37).

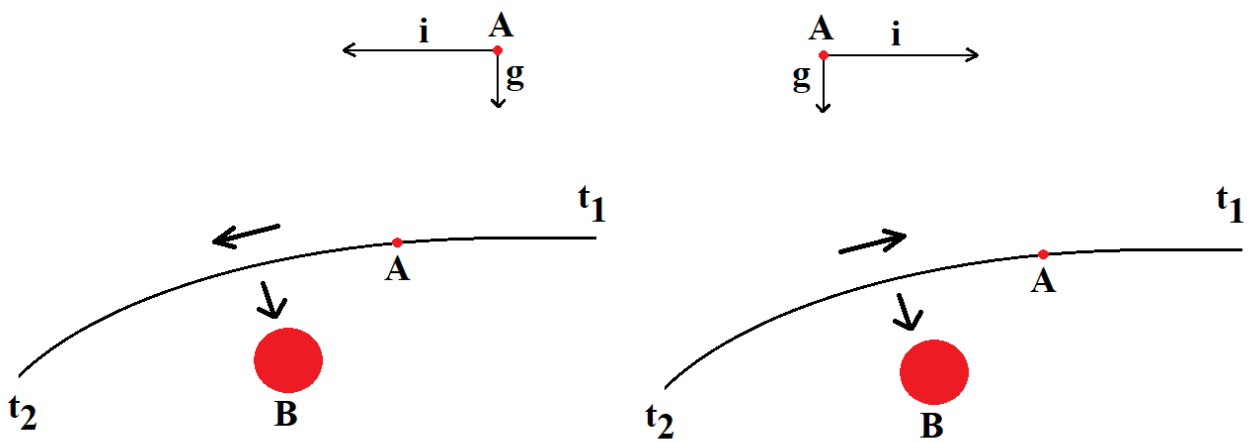

Figure 37 – On the left: the body A shows two movements: the inertial motion (i) and the displacement (g) towards the body B caused by the gravitational “force”. On the right: by inverting the time coordinates of reference, the motion (i) is inverted while the displacement (g) is not inverted.

There is an apparent contradiction: while the inertial motion reverses its direction, the gravitational “force” does not reverse its direction. According to the Einsteinian theory, which explains the contradiction, there is no gravitational force: the body A follows a geodesic, that is the shortest line in the warped space, and this geodesic does not change if the time coordinates of reference are reversed. This indicates that the gravitational “force” is indifferent as regards the direction in the Time dimension. Likewise, it also indicates that it is not possible to use the gravitational “force” to reverse the displacement of a body in the Time dimension.

Let us now consider, as regards the Time dimension, two bodies, one of which with inertial motion that is modified by an electrical “force”. It is well known that the attraction or repulsion between two electrically charged bodies is described by the Coulomb’s equation.

Imagine that the body B is rigidly attached to a support and has an electric charge of one of the two possible signs (for example, positive), while body A has an opposite electric charge and an inertial motion that leads it to pass close to B. Due to the action of the electric “force”, the motion of A is deflected towards B. By inverting the time coordinates of reference, the direction of the inertial motion of A is inverted while the electrical “force” does not show an inversion.

Here, too, we have an apparent action from a distance. In the same way of the explanation for the gravitational “force”, it has been previously proposed that the electric “force” is the effect of the

distortion of a different dimension (the “Electric” dimension), which causes the convergent deviation of bodies with opposite electric charge.

Likewise, if A and B have electric charges of the same sign, it has been proposed that the distortion of the “Electric” dimension causes a divergent deviation of the two bodies.

In both cases, the electrical “force” does not reverse with the inversion of the time coordinates of reference. Even in these cases we cannot use the electrical “force” to invert the movement of a body in the Time dimension.

With similar reasoning, following the explanations proposed regarding: (i) attraction between two bodies composed of antimatter; (ii) repulsion between matter and antimatter; (iii) weak force; (iv) strong force; and (v) forces of the three colors of the quarks, we always have deviations (converging or diverging depending on the case) which are determined by distortions of specific dimensions and are not reversed by the inversion of the time coordinates of reference. Even in these cases we cannot use these “forces” to invert the movement of a body in the Time dimension.

In short, we cannot use either the inertial motions of bodies moving forward in the Time dimension or any “force” to change the motion of a body from forward to backward in the Time dimension.

Really, the mystery lies not in the practical impossibility of determining the movement of a body in a backward direction in the Time dimension but in the fact that all the bodies we experience move in a forward direction in the Time dimension.

It is likely that this is justified by the origin of our sub-universe from an event, the Big-Bang or something similar, which for all the “particles” has determined from the beginning a forward movement in the Time dimension. It should be noted that here no hypothesis is proposed regarding the genesis and characteristics of the Big Bang or in any case about what generated our sub-universe. It should also be emphasized that if - by imaginative hypothesis - we were able to send back in Time a body, for example an atom, it would be inverted in all its “particles”, i.e., each of its “particles” would become its “antiparticle” (for example, the proton in antiproton, etc.), and therefore annihilation phenomena would occur in case of contact with ordinary atoms.

It is useful a brief mention of a particular type of common phenomena, i.e., those that determine an increase in entropy, which could cause some misunderstanding.

Let us consider a container where there is a particular gas and in which a hole is opened. It is well known that the gas will diffuse in the air and that the reverse will never happen. This is easily explained by the lower entropy of the gas in the container and the greater entropy of the gas diffused in the air and with the fact that, for mere probabilistic considerations, the entropy – i.e., the degree of disorder - always tends to increase (Second Law of Thermodynamics).

If it is true that the two directions of time dimension are perfectly equivalent, it could be objected that the increase in entropy should also occur in the backward direction of time.

Brian Greene, in chapter 6 of his popular book (2005), observes as an explanation that in the early stages of the universe entropy was minimal and in subsequent times it has always increased. For this reason, entropy increases in the forward direction of time.

This explanation, however, requires an integration. All the gas molecules in the container, like any “particle” of our sub-universe, show forward motion in the Time dimension from the primordial origins. If they had backward motion, the increase in entropy, or the diffusion of the gas in the atmosphere, would occur backward in the Time dimension (Fig. 38). In short, the forward direction of entropy increase does not depend on a peculiar asymmetry of the Time dimension but on two factors intrinsic to the same primordial origins of our sub-universe: (i) the minimum entropy at the time of the Big Bang; and (ii) the forward direction in the Time dimension determined by the Big Bang for all “particles”.

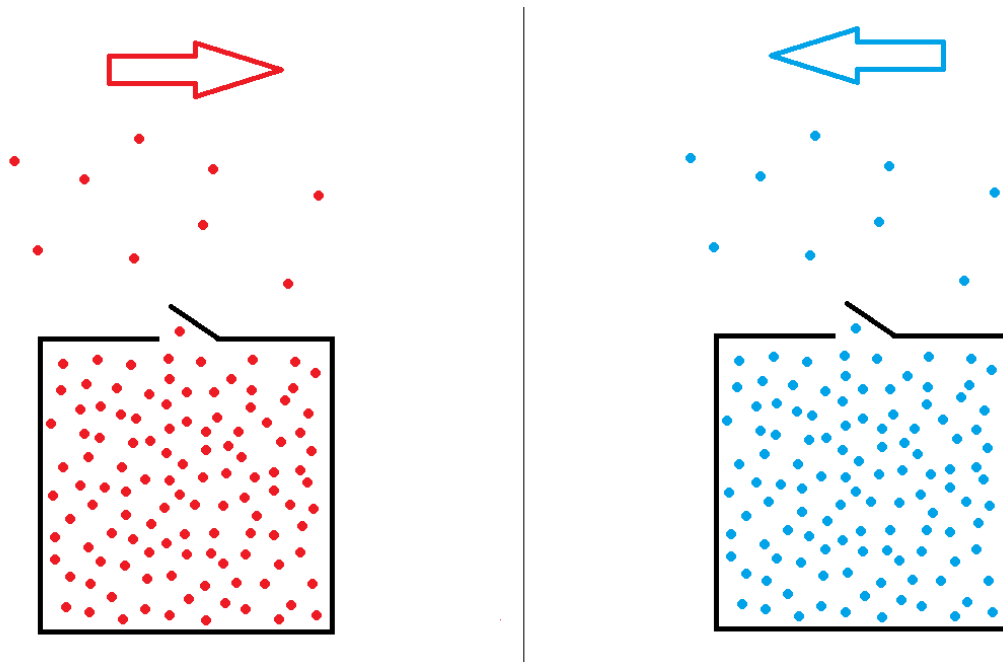

Figure 38 - On the left: all the molecules in the container have forward motion in the Time dimension (symbolized by the red color). When a hole is opened in the container, the molecules spread outwards, due to the effect of the Second Law of Thermodynamics, increasing entropy in the forward direction of Time. On the right: all the molecules in the container have backward motion in the Time dimension (symbolized by the blue color). When a hole is opened in the container, the molecules spread outwards, increasing entropy in the backward direction of time.

### 23. Subdivision of a dimension

The subdivision of any dimension of our sub-universe appears possible only within the limits determined by the well-known quantization of all phenomena.

Such quantization is so pervasive that theories have been proposed in which space and time (and potentially any other dimension) are granular entities. With this setting, this graininess is the primary cause of the quantization of phenomena and at the same time also a basis for the definition of any phenomenon and for the general description of the universe.

In the interpretation that has been proposed in the previous pages, the quantization of phenomena is not a primary characteristic of any dimension but only the consequence of the existence of an extremely small dimension, the Planck dimension. Without this dimension the phenomena would not be quantized and there would be phenomena in which there are segments of sub-quantum length for any dimension.

Conceiving sub-quantic distances might seem an abstract hypothesis and without any real confirmation.

Yet even with the quantization of phenomena such distances must necessarily exist, as it is easy to deduce from simple reasoning.

Let us consider a segment of a dimension that oscillates, thus forming a wave. As a consequence of the quantization of the phenomena, the wave will have a height  $H$  which can only be an integer multiple of the Planck length ( $l_p$ ). But the wave is a continuous line that, on both sides, goes from a height  $H$  up to a height of zero, passing through all the infinite intermediate heights that do not necessarily always respect the condition of being multiple integers of  $l_p$ . Alternatively, we should imagine that the wave has the height  $H$  in the center and then passes to zero by vertical steps, gradually reducing the height with unit decreases equal to  $l_p$  (Fig. 39). This alternative does not appear likely.

Consequently, it is more rational to imagine each dimension as something without any graininess, that is, without any limitation in its degree of possible subdivisions, despite having limits imposed in many cases by the existence of a much smaller dimension.

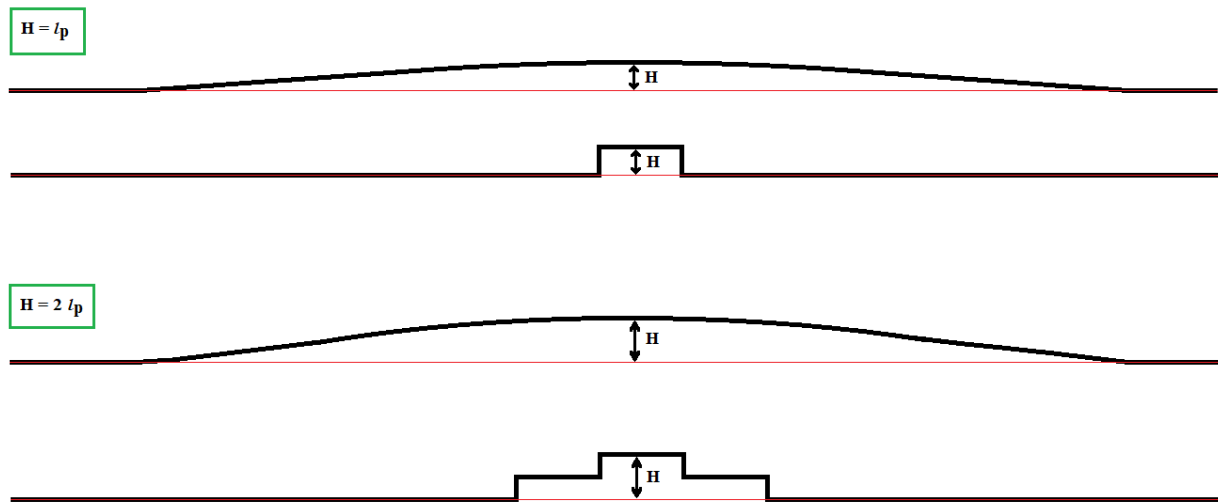

Figure 39 - Above, a wave with maximum amplitude ( $H$ ) equal to a Planck length ( $l_p$ ). If the dimensions in which the wave widens in the transverse directions were not infinitely divisible, the amplitude should go from  $H$  to 0 with a single step of height  $l_p$ . Below, a wave with  $H = 2 l_p$ . In this second case the wave should go from  $H$  to 0 with two steps of height  $l_p$ .

These considerations allow to overcome a well-known contradiction between the theory of general relativity and the quantization of phenomena:

“Imagine having a ruler in your hand, according to special relativity, an observer who looks at us while moving in a rectilinear motion at a constant speed (close to that of light) would see the ruler shorter than we see it. But what if the ruler is as long as the fundamental scale? For special relativity, however, it would be shorter than this unit of measurement for the other observer. It is therefore clear that special relativity is incompatible with the introduction of a basic grain of the Universe. Assuming the existence of this basic scale, physicists say, means violating the Lorentz invariance, a founding principle of special relativity.” (from the site <https://www.sissa.it>; 22 April 2016 - Relativity and quantum mechanics: a non-local combination? Access on 03/10/2022)

Given that for some models of quantum gravity the spacetime plot must be “grainy” on very small scales, i.e., below the so-called Planck scale ( $10^{-33}$  cm), another article available on the internet (<https://www.media.inaf.it/2011/07/01/lo-spazio-e-fatto-a-grani/>; accessed on 3/10/2022) tells us about an observation (P. Laurent, D. Götz, P. Binétruy, S. Covino, and A. Fernandez-Soto. Constraints on Lorentz Invariance Violation using integral / IBIS observations of GRB041219A. Phys. Rev. D 83, 121301(R) - Published 28 June 2011) under which the space graininess, if any, is at least 14-15 orders of magnitude smaller than the Planck scale:

<<<

*THE “INTEGRAL” SATELLITE TRIES ANSWER THE QUESTION*

***Is space made of grains?***

*First conclusions after the measurements made by the satellite. For Stefano Covino of INAF: “Either the grains of space are smaller than assumed, or the expected effects due to granulation must be reviewed.”*

*Luca Nobili 01/07/2011*

*For Einstein’s Relativity space is continuous. For quantum theories, on the other hand, it is grainy like the sand of the sea: in practice, at the microscopic level, not all positions in space are allowed*

*but only some. Trying to reconcile these two opposing views is the INTEGRAL satellite, whose latest measurements give us two possibilities: either these grains of space are much smaller than assumed, or the theories that predict the existence of certain effects due to graininess are not correct.*

*The conclusion is based on the hypothesis that the graininess of space has detectable effects on the radiation that passes through it, the more marked effects the more intense the radiation and the greater the distance it has traveled. For this reason, very distant and very energetic sources of radiation were sought, as in the case of Gamma Ray Bursts, sudden flashes of gamma radiation often produced by the explosion of stars at the end of their evolution. In the end, the choice fell on GRB 041219A, one of the most intense gamma-ray bursts ever recorded, 300 million light years away. INTEGRAL was used to measure the gamma radiation: the satellite dedicated to the study of the great energy phenomena occurring in the Universe guarantees measurements 10,000 times more accurate than its predecessors, thanks to the on-board instruments created by the collaboration of Italian institutes including the INAF. The graininess of the space should have caused effects on the radiation coming from GRB 041219A: in particular, a variation in the polarization of the electromagnetic waves that make up this radiation was expected, that is, a variation in the direction of oscillation of the waves. But nothing was found.*

*“This result can have two interpretations”, comments Stefano Covino of the INAF-Astronomical Observatory of Brera, one of the researchers involved in the study and one of the authors of the related article published in Physical Review. “First interpretation: we do not yet have the necessary technology to detect these effects. Which means that the sizes of the space grains are much smaller than assumed, less than  $10^{-48}$  meters. This places a very strong constraint on theories that describe the graininess of space, because in practice they make reliable those that foresee dimensions lower than this value, while forcing some of the others to be heavily revised”.*

*However, there is also a second possibility: “We must remember that we do not yet have universally accepted theories that tell us how space is quantized. The fact that INTEGRAL did not measure the variations in the polarization of the gamma radiation could also mean that the effects predicted by the theories that predict graininess are not correct. In this case it will be necessary to focus on other theories that foresee other effects.”*

>>>>

The most logical conclusion appears to be that of considering with great caution theories as those of quantum gravity that attempt to adapt general relativity to quantum theory. On the contrary, if the origin and characteristics of all the “forces” are considered, as previously outlined, in a single theoretical context as a consequence of the existence of several dimensions, the quantization of the phenomena is the effect of the existence of a very small dimension and not a primary characteristic of the universe.

## **24. The infinite**

In general, there are finite quantities in current physical descriptions. Furthermore, where there are infinite values, it seems justified to eliminate or circumvent these values by means of artifices.

In the arguments of these pages, the concept of infinite entities often recurs. In particular:

- infinite dimensions;
- infinite subgroups of these dimensions, each with a finite number of dimensions;
- each dimension is limitless;
- each dimension is infinitely divisible.

However, there are numerically finite phenomena:

- where there are limited parts of an infinite set. For example, each sub-universe is a finite subset of some dimensions among the infinite dimensions of the universe;
- where there are relationships between dimensions. A dimension can be a finite fraction of another dimension, not excluding by this that both dimensions are limitless. Finite relationships between

dimensions are the origin of phenomena of finite size. For example, in our sub-universe, a dimension that is very small compared to the others determines the phenomena described as the quantization of phenomena.

Therefore, if we want to describe the universe with a single term, the concept of infinity appears appropriate.

## 25. Conclusion

Some of the main hypotheses, arguments and deductions worked out in the previous pages:

- (1) [Postulate] There are infinite dimensions and infinite subsets of these dimensions, definable as sub-universes, each consisting of a limited number of dimensions.
- (2) [Postulate] Each dimension has a curvature defined by its radius, which is in the range between  $+\infty$  and  $-\infty$ . Also, being curved, they are unlimited. The difference between “positive” and “negative” curvature is postulated in the effects shown when the curvature is flattened in a segment but no explanation for this difference is suggested.
- (3) [Postulate] There is no difference between the two possible directions of any dimension. From this it follows that the set of all dimensions, or even any of its sub-sets, does not have any kind of polarity and that the infinite dimensions are all orthogonal to each other.
- (4) [Postulate] Since there are no terms of comparison other than the dimensions, each dimension is infinite and infinitely divisible. However, the ratios between two or more dimensions are finite terms.
- (5) All the properties of each sub-universe (the so-called “constants of Nature” included) depend solely on its constituent dimensions (i.e., number of the dimensions and curvature of each of them).
- (6) There are no “elementary particles” but only double oscillations (which are rotations if the oscillations are asynchronous) of segments of a dimension. Consequently, there are not even “complex particles” (aggregates of several “elementary particles”) but only aggregates of double oscillations of segments pertaining to various dimensions. The terms “elementary particle” and “complex particle” can be used for simplicity of expression but only within the limits of the aforementioned meanings and never considering a particle as an entity distinct from any dimension. Similarly, the matter, defined as a set of simple or complex “particles”, does not exist as an entity in its own right and distinct from any dimension.
- (7) The gravitational “force”, and similarly the “forces” defined as electromagnetic, weak, strong, and those related to the “colors” of the quarks, and any other force in our sub-universe (and in any other sub-universe) do not exist as distinct entities and represent only convergent (“attractive”) or divergent (“repulsive”) deviations consequent to the local flattening of the curvature of a dimension. The term “force” can be used for simplicity of expression, always remembering the aforementioned meaning.
- (8) Regarding the “force” of gravitation, and similarly for any other “force”, there is no “field” of gravity or any other force. The concept of “field” is a mathematical/geometric tool that can simplify the calculation of the effects of a “force” but must never be conceived as something distinct and with its own nature. Similarly, the concept of “vector” must be considered only as a mathematical/geometric tool that is useful for the calculation of the effects of a “force”.
- (9) The “constant” in the mathematical description of an attractive or repulsive “force” in a dimension: (i) is a function of the curvature of the dimension; (ii) has a constant value only for a given radius of the dimension; and (iii) changes if the curvature of the dimension changes.
- (10) Each “constant” for the attraction/repulsion in a dimension between two “particles” is reduced as the distance between the two “particles” in the aforementioned dimension increases and becomes zero when the distance is equal to the semicircle of the dimension ( $\pi \cdot R_X$ ; no distance greater than the semicircle is possible). This explains the small range of “forces” much more intense than the gravitational “force” at the scale of the atom or nucleus and at the same time explains the enormous range of the gravitational “force”.



Moreover, as the absolute value of  $R_X \rightarrow \infty$ , the “force”  $\rightarrow 0$ .

- (11) The maximum speed in a dimension is a direct function of the radius of the dimension, (i.e., an inverse function of the curvature). The speed of light is a function of the curvature of the three Spatial dimensions. In dimensions with much less curvature than that of the Spatial dimensions the maximum speed is much greater than that of light. The double oscillations which constitute the “particles” occur in dimensions with infinitesimal or zero curvature and therefore with a maximum speed much higher than that of light. This apparently infinite maximum speed can be the basis for the explanation of entanglement phenomena as an alternative to implausible effects of actions at a distance.
- (12) In our sub-universe the quantization of any phenomenon is a consequence of the existence of a dimension with extreme curvature (i.e, with a very small radius; Planck dimension) and not of a hypothetical granularity of space and time. As each dimension, whatever its curvature, is conceived as something infinitely divisible, in our sub-universe phenomena would not be quantized without the Planck dimension.
- (13) It is possible to deduce the characteristics of protons, neutrons, electrons, etc. by the characteristics of the dimensions in our sub-universe. In particular, the electron is not a simple “particle” but should be the combination of three triplets of double oscillations.
- (14) Heisenberg’s principle, that is, the impossibility of calculating two correlated physical properties of a “particle” with precision greater than a certain minimum value, is based on the erroneous postulate of the existence of “particles” in the meaning of distinct entities.
- (15) The precise knowledge for a definite instant of the state of an elementary “particle” A, correctly understood as the double oscillation of a segment of a single dimension, is impossible because if we use any other “particle” B as a scanning element we do not have precise knowledge of B and therefore the result has a similar uncertainty. Besides, any attempt at measurement alters the state of the “particle” A. Similarly, precise knowledge for a definite instant of the state of a complex “particle” is impossible.
- (16) In the current description of a Black Hole, within the event horizon there is an increasing force of gravity going towards its geometric center where the force becomes infinite and determines a so-called singularity. On the contrary, here it is proposed that the force of gravity decreases going towards the center of the Black Hole where it zeroes with no singularity existing in that point. The two opposite explanations arise from two opposite premises. In fact, in the Einsteinian conception - previous to the discovery of the expansion of the Universe (as a bubble that inflates) - the space without “masses” (not better defined) is flat and the “masses” warp the space causing the gravitational “force”. Moreover, as the masses thicken, the distortion of the space and the force of gravity grow reaching infinite values according to the Einsteinian equations. On the contrary, in the explanation proposed here the dimensions are curved in the absence of “masses”, the masses are defined as double oscillations of the Spatial dimensions that flatten the curvature of the Spatial dimensions and the gravitational “force” can grow only up to the maximum possible flattening, thus completely excluding the possibility of an infinitely increasing gravitational force.
- (17) Electromagnetic waves, even though - by definition - in the void have a speed equal to that of light, do not show any shortening in the direction of movement as there are no oscillations of the Spatial dimensions in them.
- (18) No proposal has been made regarding the origin of the sub-universes, or in particular regarding the Big-Bang for our sub-universe.

Wanting to have a synthetic picture of the possible answers to the questions highlighted in the Introduction, on the basis of the arguments reported above we have:

	Questions highlighted in the Introduction	Explanations proposed in this book
1	What are the electromagnetic force, the strong force, the weak force and the	For each dimension X - Electric (E) / Strong (S) / Weak (W) / Red (R) / Green (G) / Blue (B) - a flattening (determined by the oscillation

	red/green/blue forces acting within the nucleus?	of a segment of X) causes changes in the geodesics of X and therefore convergent or divergent deviations for other oscillations of the same dimension X. These deviations can be described as “forces” but the term can be misleading if their origin and nature are not considered. Common characteristic of these “forces” is that they do not reverse their direction if we reverse the time coordinates of reference.
2	Why do electric charges of the same sign repel each other while electric charges of opposite sign attract each other?	Considering a dimension with negative curvature, defined as Electric dimension (E), oscillations with the same direction of rotation (clockwise or anti-clockwise) repel each other while oscillations with opposite direction of rotation attract each other.
3	Which is the difference between positive and negative electric charges?	Positive and negative electric charges are oscillations of the Electric dimension with opposite direction of rotation. They can be defined as “particle” and the respective “anti-particle”. The distinction between them is arbitrary: by custom, the electron with negative electric charge is defined as particle while the positron with positive electric charge is considered as anti-particle.
4	Why do not electrons with their negative charge fall on the surface of the nucleus that has a positive charge?	Electrons are not a simple structure. In addition to 3 negative oscillations of the Electrical dimension (“particles” E-), which if present alone would move away from each other, they also consist of three positive oscillations of the Strong dimension (Strong, S) with positive curvature (“particles” S+), which have two effects: 1) they are attractive to each other surpassing the disintegrating effects of the “particles” E-; 2) they are repulsive towards the “particles” S- present in the nucleus, surpassing the attractive effects between “particles” E- of the electron and “particles” E+ of the nucleus. For this reason, electrons cannot adhere to the surface of the nucleus.
5	What are the colors of a quark?	In analogy with the names of the three primary colors of light, it is an arbitrary way to name three distinct dimensions with pronounced negative curvature: Red (R), Green (G), and Blue (B), which give the quark a characteristic defined as “color”. Since the curvature is negative, oscillations in the same direction of rotation repel each other. Furthermore, as the curvature is accentuated, the repulsive “force” is very strong but with a very limited range of action.

6	Why are protons and neutrons composed of three quarks and not of a different number of quarks?	It is likely that the repulsive forces between quarks of the same color are too strong to allow the presence of two quarks with the same color within a single proton or neutron. Therefore, as the dimensions defined as “colors” are three, a configuration with four “colors” would not be stable.
7	Why do quarks have electric charges that are a third or two thirds of that of electron or positron?	The tertiary charges of the quarks are the true units of the electric charge while the electric charges of the electron or positron are equal to three tertiary electric charges (negative and positive, respectively). It is likely that three tertiary electric charges in the same quark are an unstable aggregate due to the excessive repulsive “force” between charges of the same sign.
8	Why are all phenomena quantized?	It is likely that there is a dimension with an extremely small radius (Planck dimension, P) that is not significantly deformable by the action of “forces” determined by oscillations of other dimensions with a much greater radius. Consequently, all other dimensions cannot “fold” into segments such as to crush the P dimension.
9	Why do the values of light speed, Planck constant, universal gravitation constant, and electron charge have certain values?	These universal constants depend on the radii of curvature of the dimensions. Our sub-universe is defined in its characteristics by: (i) the number of its dimensions; (ii) their curvatures; and (iii) that set of events of unknown origin defined as the Big Bang.
10	How are the phenomena generally described as “entanglement” justified?	Excluding the hypothesis of actions at a distance, the phenomena generally described as “entanglement” require much higher propagation speeds than that of light. This is possible only by assuming dimensions with minimum or zero curvatures (dimension L and dimension L') in which the maximum speed is much higher than that of light.
11	Which is the nature of an electromagnetic wave?	They are oscillations of segments of the two entanglement dimensions (L and L') that run in the Spatial or Newtonian dimensions.
12	Why do electromagnetic waves, which run at the speed of light in a vacuum, do not shorten in the direction of their movement as occurs for any mass according to the theory of relativity?	The entanglement dimensions (L and L') are not subject to the relativistic shortening in the direction of the displacement as a function of Lorentz transformations.
13	Why are the weak force and the strong force extremely strong inside the nucleus and at the atomic level, respectively, but become irrelevant at slightly greater distances, while the gravitational force is extremely weak and	The weak “force” and the strong “force” are the effects of flattening in dimensions with very small radii of curvature while the gravitational “force” is the effect of flattening in the three Spatial or Newtonian dimensions

	negligible at the atomic level but does not lose its attractive capacity even at distances of billions of light years?	with a common value of the radii of curvature that is many orders of magnitude larger than the other two dimensions. Consequently, the first two forces are extremely more intense than the gravitational force but their range of action is extremely limited. The opposite occurs for the gravitational force: very small intensity but very large range of action.
14	If it is true that in a Black Hole and in the singularity that is at its center all information is lost, how is this phenomenon justified?	A Black Hole is a neutron star with a mass such that the gravitational acceleration at its surface is equal to the speed of light, which is the maximum possible value for the gravity. Below its surface gravity decreases linearly in the direction of the center where it zeroes. There is no infinite gravity or infinite densification at the center of the Black Hole forming the so-called singularity and therefore there is no loss of information.

## 26. Post scriptum

I do not know for sure the validity of what I have written and proposed in these pages.

It could be a delirium with a certain internal coherence, that is to say the product of a paranoid ideation, or on the contrary something rational and innovative for Physics.

However, an Author certainly cannot be objective in evaluating what is proposed.

I hope that what is suggested be a stimulus for scholars with much greater skills and experience for the development of better and more valid solutions about the certain shortcomings of modern physics.

## 27. References

- Al-Khalili J (1999) *Black Holes Wormholes & Time Machines*, Taylor & Francis Group, New York.
- Barrow JD (2002) *The Constants of Nature. From Alpha to Omega*, Jonathan Cape, London.
- Barrow JD, Tipler FJ (1988) *The Anthropic Cosmological Principle*. Oxford University Press. ISBN 978-0-19-282147-8. LCCN 87028148.
- Bernard Cohen I, Whitman A (translation by) (1999) *Isaac Newton, The Principia: Mathematical Principles of Natural Philosophy*, University of California Press.
- Cabbolet MJTF (2011) Comment to a paper of M. Villata on antigravity. *Astrophysics and Space Science*. 337(1):5-7. doi:10.1007/s10509-011-0939-8.
- Carter B (1974) Large Number Coincidences and the Anthropic Principle in Cosmology. IAU Symposium 63: Confrontation of Cosmological Theories with Observational Data. Dordrecht: Reidel, pp. 291-298; republished in *General Relativity and Gravitation* (Nov. 2011), Vol. 43, Iss. 11, p. 3225-3233, with an introduction by George Ellis.
- Carroll SM (2004) *Spacetime and Geometry*. Addison Wesley, p.205. ISBN 0-8053-8732-3.
- Dove J, Kerns B, McClellan RE, *et al.* (2021) The asymmetry of antimatter in the proton. *Nature* 590:561-5. doi: <https://doi.org/10.1038/s41586-021-03282-z>.
- Einstein A (1916) Die Grundlage der allgemeinen Relativitätstheorie. *Ann Phys* 354:769-822. DOI: 10.1002/andp.19163540702.
- Einstein A (1971) *The Born-Einstein Letters; Correspondence between Albert Einstein and Max and Hedwig Born from 1916 to 1955*. Walker, New York, Letter from Einstein to Max Born, 3 March 1947.
- Einstein A, Rosen N (1935) The Particle Problem in the General Theory of Relativity. *Phys. Rev.* 48(73).
- Everett H, Wheeler JA, DeWitt BS, Cooper LN, Van Vechten D, Graham N (1973). DeWitt B, Graham RN (eds.). *The Many-Worlds Interpretation of Quantum Mechanics*. Princeton Series in Physics. Princeton, NJ: Princeton University Press.
- Flamm L (1916) Beiträge zur Einsteinschen Gravitationstheorie (Comments on Einstein's Theory of Gravity). *Physikalische Zeitschrift*. XVII:448.
- Greene B (2005) *The fabric of the cosmos*, Vintage books, New York.
- Hawking S (1998) *A brief history of time*. Bantam Books, New York.
- Heisenberg W (1927) *Über den anschaulichen Inhalt der quantentheoretischen Kinematik und Mechanik* [On the intuitive content of kinematics and mechanics in quantum theory], in *Zeitschrift für Physik*, vol. 43, n. 4, pp. 172-198.
- Hooft G (1997) *In search of the ultimate building blocks*. Cambridge University Press, UK.
- Juan Y, Yuan C, Hai-Lin Y, *et al.* (2013) Bounding the speed of 'spooky action at a distance'. *Physical Review Letters*. 110(26):260407.
- Kalogera V, Baym G (1996) The Maximum Mass of a Neutron Star. *The Astrophysical Journal*. 470:L61-4. doi:10.1086/310296.
- Kaluza T (1921) Zum Unitätsproblem der Physik, *Sitzungsberichte Preussische Akademie der Wissenschaften*, 96.
- Kennard EH (1927) Zur Quantenmechanik einfacher Bewegungstypen, *Zeitschrift für Physik* (in German), 44(4-5):326-52, doi:10.1007/BF01391200.
- Kisak PF (ed.) (2016) *Quantum entanglement: "... spooky actions at a distance."* CreateSpace Independent Publishing Platform, Lexington, USA.
- Klein O (1926) *Zeitschrift für Physik*, 37, 895; English translation in Klein O, *The Oskar Klein Memorial Lectures*, edited by Ekspong G, Singapore, World Scientific, 1991.
- Lemaître G (1927) Un Univers homogène de masse constante et de rayon croissant rendant compte de la vitesse radiale des nébuleuses extra-galactiques. *Annales de la Société Scientifique de Bruxelles*, 47:49-59.
- Matson J (2012) Quantum teleportation achieved over record distances. *Nature News*. doi:10.1038/nature.2012.11163.

- Moring G (2001). *The Complete Idiot's Guide to Theories of the Universe*. Penguin, pp. 192-193.
- Newton I (1726) *Philosophiae Naturalis Principia Mathematica*, General Scholium. Third edition.
- Patrignani C, et al. (Particle Data Group) (2016) Review of Particle Physics, *Chinese Physics C*, 40(10), 100001. DOI: 10.1088/1674-1137/40/10/100001.
- Randall L (2005) *Warped passages: unraveling the mysteries of the universe's hidden dimensions*, Harper Collins.
- Rohlf JW (1994). *Modern Physics from a to Z<sup>0</sup>*. John Wiley & Sons.
- Sakurai JJ, Napolitano J (2020) *Modern Quantum Mechanics* (3rd ed.), Cambridge University Press.
- Santilli RM (1999) A classical isodual theory of antimatter and its prediction of antigravity. *International Journal of Modern Physics A*. 14 (14):2205-38. doi:10.1142/S0217751X99001111.
- Schrödinger E (1935). "Die gegenwärtige Situation in der Quantenmechanik (The present situation in quantum mechanics)". *Naturwissenschaften*. 23(48): 807-12.
- Schwarzschild K (1916) On the Gravitational Field of a Point Mass in Einstein's Theory. *Proceedings of the Prussian Academy of Sciences*, 424.
- Seeds M, Backman D (2009). *Astronomy: The Solar System and Beyond* (6th ed.). Cengage Learning.
- Susskind L (1995) The World as a Hologram. *Journal of Mathematical Physics*. 36(11):6377-96. doi:10.1063/1.531249.
- Teramoto Y (2015) *Elementary particle physics for enthusiasts*. CreateSpace Independent Publishing Platform.
- Veltman M., *Facts and mysteries in elementary particle physics*, World Scientific Publishing, 2003.
- Villata M (2011) CPT symmetry and antimatter gravity in general relativity, *Europhysics Letters (EPL)*, 94(2):20001, doi: 10.1209/0295-5075/94/20001.
- Villata M (2011b) Reply to 'Comment to a paper of M. Villata on antigravity'. *Astrophysics and Space Science*. 337(1):15-7. doi:10.1007/s10509-011-0940-2.
- Villata M (2013) On the nature of dark energy: the lattice Universe. *Astrophysics and Space Science*. 345(1):1-9. doi:10.1007/s10509-013-1388-3.
- Villata M (2015) The matter-antimatter interpretation of Kerr spacetime. *Annalen der Physik*. 527(7-8):507-12. doi:10.1002/andp.201500154.
- Walker J (ed.) (2014) *Fundamentals of Physics Halliday and Resnick*, 10th ed., Wiley, New York.

## Appendix 1

After writing these pages, for months I was unsure if I could go further by publishing them in some way or, more prudently, I had to keep them carefully hidden in a drawer. What had I written? Something interesting or a seemingly coherent set of nonsense, i.e., the result of an original form of scientific paranoia. After much hesitation, which I hope will be forgiven in the first case and which is my partial defense in the second case, I decided to make them public after reading the interesting general considerations of Scott S. Gordon, another non-professional physicist (of whom, to avoid any doubt, I specify that I do not share the theories he proposes). I report below these considerations which for me were of great interest and usefulness.

### **The Theory of Everything... What Took So Long!** [Scott S. Gordon]

*“The most important thing in science is not so much to obtain new facts as to discover new ways of thinking about them.”* [Sir William Bragg]

...

After general relativity and quantum mechanics were generally accepted, it was thought that grand unification and the theory of everything could not be far off. Yet, the struggle to find the theory of everything persisted over the past 100 years. Why this theory has been so elusive is easy to see in hindsight and the top 10 reasons are listed below:

#### **1) Faulty Postulates Used to Derive General Relativity and Quantum Mechanics**

Theories are used in physics which are expressed in mathematics. A theory starts with postulates which are expressed in mathematical terms which are then used to derive equations representing the theory which can be tested. Just like all theories, general relativity and quantum mechanics are derived from their respective postulates. These strong theories were subsequently used to develop much of the mathematics we use to describe the physics we understand today. The problem is these theories do not work well together in solving the “big” picture and yet it seems that they should. We need to consider that if these two strong basic theories cannot be united, then there must be something fundamentally flawed with the postulates used in deriving them.

If inaccurate and/or incomplete postulates were used to build our strongest theories which form the basis of all our physics, then there is a major problem in our current foundation of physics. Physicists are using the mathematics derived from this false foundation to try and solve the theory of everything. These attempts are doomed to fail. Physicists will not succeed until they first fix the flawed postulates used to derive relativity and quantum mechanics. Trying to fix these postulates by using the mathematics derived from them is not possible! In order to unite relativity and quantum mechanics, the postulates on which they were built must be modified. The modifications need to be done in such a way so that relativity and quantum mechanics remain basically intact; similar to how Einstein’s theory of special relativity modified Newtonian physics. The only way to achieve this goal is to find the primordial postulates for the theory of everything and then derive the corrected postulates for general relativity and quantum mechanics.

We should take note that the postulates used to derive relativity and quantum mechanics are expressed in simple mathematics. We should therefore expect that the primordial postulates of the theory of everything to be expressed in simple mathematics. This is in direct contradiction to those who are using the complex mathematics derived from relativity and quantum mechanics to solve the theory of everything.

#### **2) The Sub-Specialization of Physicists**

The specialization of physicists within a specific area of research makes it extremely difficult to consider the big picture. In the medical field, the specialists take care of specific areas of medicine or surgery. Unlike the internist or family physician, they usually do not treat a patient’s overall medical condition. In comparison, a physicist may want to work on a specific problem in physics such as inflation at the time of the Big Bang, or gravity; but physicists have to work within the confines of our existing mathematics and current theories.

Our current theories are missing “something” because there is something missing from the flawed postulates from which they were derived. It is not likely that physicists working under these conditions would find a new mathematical basis of understanding. If you can only use the flawed mathematics of established theories, then you can only come up with a flawed answer that serves as a “patch-like solution” to a problem. This is what has been happening in physics; “sub-theories” based on our current mathematics are used to explain specific phenomena such as the black holes, inflation, expansion, mass, and many others.

Physicists then attempt to stitch together a tapestry of patch-like solutions to create a complete picture of the universe. This piecemeal approach will not be helpful in figuring out the theory of everything. In addition, physicists should realize that all the mathematical efforts put into analyzing Feynman diagrams also fall subject to this problem. The solutions to Feynman diagrams will not be helpful in solving the theory of everything.

### **3) The Selection Process to Become a Physicist**

The path to become a physicist includes an intense training and selection process. Only those who are the best at the required skills will earn the title of *physicist* and be allowed into “the academic club” of physicists. Many believe that a diverse academic physics community would be helpful in bringing forth the solution to the theory of everything where diverse backgrounds foster diverse ideas. However, people of different backgrounds who have gone through the intense selection process to become an academic physicist also become part of ... the collective “mind” of physicists. In other words, they all have become physicists and thus “think” like physicists using the established theories and mathematics they have learned in the process.

*“Man (or woman) is not permitted without censure to follow his (or her) own thoughts in the search of truth, when they lead him (or her) ever so little out of the common road.”* [John Locke, *An Essay Concerning Human Understanding*]

...

### **4) Space-time is a Medium**

A very important obstacle in solving the theory of everything is the indoctrination of almost the entire physics community onto the wrong path over 100 years ago. Ask the “collective mind” of physicists whether space-time is a medium and the answer you get is “no!” If the answer is actually “yes”, then there is no way to ever solve the theory of everything. Physicists believe space-time is a “void” and not a medium because of the results of the Michelson-Morley experiment. Although the data from the Michelson-Morley experiment is correct, this conclusion is incorrect. I point out that Einstein’s theory of general relativity never proved that a medium did not exist, and Einstein himself believed that theory of general relativity could not properly function without a medium. Even though Einstein and others could not find the medium, doesn’t mean that one does not exist. In any case, the notion that there is no medium was established and passed on from generation to generation, teacher to student, to the point where physicists would rather believe in multiple universe theories than go back and reconsider that there is a flaw in their current understanding.

*“It is not the things we don’t know that kill us, it’s the things we know for sure that ain’t true.”* [Mark Twain]



## Appendix 2

In geometrical terms, it is possible to conceive only three types of three-dimensional space that are symmetrical between all locations and in every direction: the classical or Euclidean space, the space with positive curvature, the space with negative curvature (Fig. 40): “*Researchers have proven that this list – uniformly positive, negative, or zero – exhausts the possible curvatures for space that are consistent with the requirement of symmetry between all locations and in all directions.*” [Brian Greene 2005, p. 241].

We can define in a common way these three types of space as one general type of spaces that differ only on the basis of the radius ( $R$ ), that is to say for the degree of curvature, or simply curvature ( $= 1/R$ ):

**- space with positive or spherical curvature ( $R>0$ ;  $1/R>0$ );**

--- a one-dimensional space with positive curvature can be represented as a circumference seen from the external side;

--- a two-dimensional space with positive curvature can be represented as the external surface of a sphere;

**- space with negative or hyperbolic curvature ( $R<0$ ;  $1/R<0$ );**

--- a one-dimensional space with negative curvature can be represented as a circle seen from the inside and with the values of the distances between the centre of the circle and the points of the circumference considered as negative;

--- a two-dimensional space with negative curvature is imperfectly represented as an infinite saddle or, for convenience of visualization, as the internal surface of a sphere or however as a concave surface and with the values of the distances between the centre of the sphere – or of the concave surface - and the points of the surface considered as negative;

**- space with zero curvature (Euclidean space) ( $R=\pm\infty$ ;  $1/R=0$ );**

--- a one-dimensional space with zero curvature can be represented as a straight line;

--- a two-dimensional space with zero curvature can be represented as a plane;

--- a three-dimensional space with zero curvature is our ordinary perception of space.

Curved spaces with more than two dimensions or with zero curvature and more than three dimensions cannot be visually represented but can be perfectly described in mathematical terms.

Multidimensional spaces in which curved spaces of various kinds are combined, including those with zero curvature, are always mathematically describable.

The three types of space (that is, with  $1/R$ :  $>0$ , or  $<0$ , or  $=0$ ) can therefore also be considered as a single type of space with only one variable (curvature,  $1/R$ ) that differentiates three subtypes. As there are infinite possible values of  $1/R$ , there are infinite possible particular spaces.

It is well known that, depending on the curvature value, all the formulas and the relative calculations deriving from this parameter are modified. An example is shown in Fig. 40.

The set of all possible geometric spaces that are symmetric between all locations and in every direction has values of  $R$  and  $1/R$  comprised between  $+\infty$  and  $-\infty$  (Table 10):

Table 10

$1/R$	$R$	Description
$<+\infty$ and $>0$	$>0$ and $<+\infty$	spaces with positive curvature
0	$+\infty$ or $-\infty$	Euclidean space
$>-\infty$ and $<0$	$<0$ and $>-\infty$	spaces with negative curvature

$$S = \sqrt{a^2 + b^2}$$

$$h > S$$



$$h < S$$

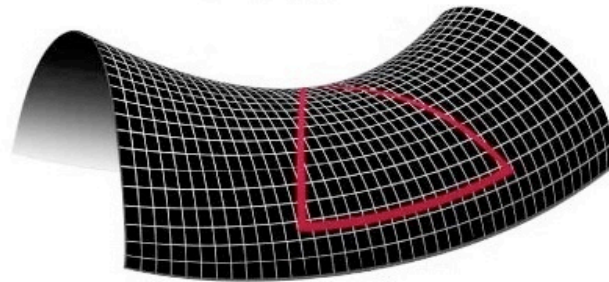

$$h = S$$

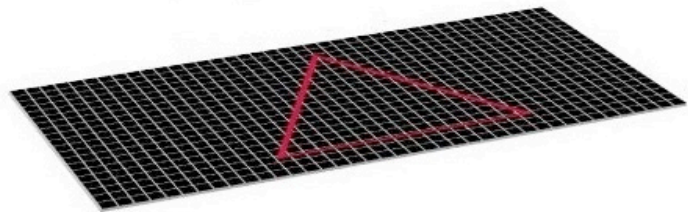

Figure 40 – The three types of space. In a two-dimensional space with zero curvature (Euclidean space, bottom), the sum of the angles of a triangle ( $A$ ) is equal to  $180^\circ$  and the hypotenuse of a right-angled triangle ( $h$ ) is equal to the square root of the sum of the squares of the catheti  $a$  and  $b$  ( $S$ ), i.e., we have  $h=S$ . In a space with positive curvature (top),  $A>180^\circ$ ,  $h>S$ , while in a space with negative curvature (in the centre),  $A<180^\circ$ ,  $h<S$ .

Copyright © 2022  
Electronically printed on December 2022  
Copernican Editions  
Naples, Italy

**ISBN 978-88906486-8-7**